



MT-4R and MT-4D P25 Digital and Analog Radio Systems

USER GUIDE



Daniels MT-4R & MT-4D P25 Digital and Analog Radio Systems

User Guide

NOTE

Copyright © 2011 Daniels Electronics Ltd. All rights reserved. No part of this publication may be reproduced, stored in a retrieval system or transmitted in any form or by any means, electronic, mechanical, photocopying, recording or otherwise, without the prior written consent of Daniels Electronics Ltd.

The stylized “Daniels Electronics Ltd.” and “DE” logo are registered Canadian and US trademarks of Daniels Electronics Ltd.

The stylized “Daniels Electronics Ltd.” and “DE” logo are trademarks of Daniels Electronics Ltd.

Motorola® is a registered trademark of Motorola, Inc.

DOCUMENT REVISION
DEFINITION

Daniels Electronics Ltd. utilizes a three-level revision system. This system enables Daniels to identify the significance of a revision. Each element of the revision number signifies the scope of change as described in the diagram below.

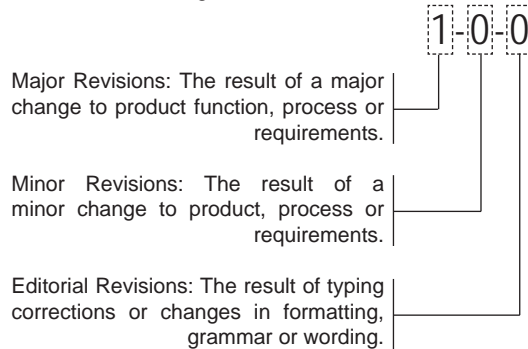

Three-level revision numbers start at 1-0-0 for the first release. The appropriate element of the revision number is incremented by 1 for each subsequent revision, causing any digits to the right to be reset to 0.

For example:

If the current revision = 2-1-1 Then the next major revision = 3-0-0

If the current revision = 4-3-1 Then the next minor revision = 4-4-0

If the current revision = 3-2-2 Then the next editorial revision = 3-2-3

Daniels Electronics Ltd.

43 Erie Street, Victoria, BC

Canada V8V 1P8

www.danelec.com

sales@danelec.com

Toll Free Canada and USA:

phone: 1-800-664-4066

fax: 1-877-750-0004

International:

phone: 250-382-8268

fax: 250-382-6139

PRINTED IN CANADA

Document Number: UG-001
Revision: 4-0-0
Revision Date: February 2011

For the past 60 years Daniels has provided customers in North America and internationally with highly reliable Base Stations and Repeaters that are environmentally robust to operate in rugged and extreme temperature conditions where low current consumption (solar powered) is a key requirement.

Daniels has been a pioneering member of the P25 Digital standard, for radio system interoperability between emergency response governmental organizations, providing enhanced functionality and encryption. Our products operate between 29 - 869 MHz and are available in a variety of Base Station and Repeater configurations for two way voice and mobile data applications.

Our self-servicing customers range from Forestry and National Park services through Police and Fire departments and on to Utility and Transportation groups. Our products have been deployed in every imaginable situation from the Antarctic to Hawaiian mountaintops to Alaska, enabling respondents to Forest Fires, Ground Zero rescue and routine patrols.

Daniels is an industry leader in Analog and P25 radio systems design. We offer modular rack-mounted Base Stations and Repeaters capable of operating in the following bands:

Low Band VHF
VHF AM
VHF FM
UHF FM
700 MHz
800 MHz

ABOUT DANIELS
ELECTRONICS LTD.

RESOURCES

Daniels Electronics Ltd. provides many resources for the testing, tuning, maintenance and design of your Daniels MT-4R and MT-4D P25 Digital and Analog Radio System.

Instruction Manuals

Daniels Electronics instruction manuals are very comprehensive and include information on:

Theory of operation
Detailed Specifications
Testing and tuning instructions
Component layout illustrations

Instruction manuals can be obtained from the factory.

Technical Notes

Technical notes outline key aspects of tuning, installing, maintaining and servicing Daniels P25 Radio Systems.

Technical Notes can be found online at www.danelec.com.

Daniels MT-4 and IFR 2975 Test Procedures (TN950)

Technical Note TN950 is an aid to configuring and testing Daniels MT-4 radios using an IFR 2975 Service Monitor by Aeroflex. TN950 is intended to be used with IFR 2975 Setup files that can be loaded into the Service Monitor.

TN950 and the Setup Files can be found online at www.danelec.com and can also be found on the Aeroflex web page at www.p25.com.

Application Notes

Application Notes provide an overview of the range of applications in which Daniels P25 Radio equipment can be used.

Application Notes can be found online at www.danelec.com.

P25 Training Guide

The P25 Training Guide provides the reader with a simple, concise and informative description of Project 25.

The P25 Training Guide can be found online at www.danelec.com.

Daniels MT-4E Analog and P25 Digital User Guide

The Daniels MT-4E User Guide provides the reader with an introduction to Daniels Electronics Ltd. MT-4E Analog and P25 Digital Radio Systems

The Daniels MT-4E User Guide can be found online at www.danelec.com.

Contents

Chapter 1: Introduction	1
Daniels Model Numbers.....	1
Differences Between MT-4R and MT-4D Series Modules.....	2
Repeater and Base Modules	3
Identifying MT-4 Model Numbers	3
Hardware, Firmware and Software Definitions	5
Available Frequency Bands	5
Chapter 2: Technical Information	7
Front Panel RJ45 Connector Jacks	7
LVDS Serial Data	8
Daniels P25 Data Packet Repeating (OTAR, GPS, etc.)	8
Mixed Mode Operation.....	9
Upgrading Firmware Versions.....	9
Repeating Digital Signals.....	11
Chapter 3: P25 Radio System Configurations	13
Repeater Operation	13
Complex Repeater Operation	14
Repeater Operation with External Analog Wireline Control	15
Analog Controlled Base Station Operation	16
Fixed Station Ethernet Interface Operation.....	18
Chapter 4: P25 System Block Diagrams	19
Repeater Block Diagram.....	20
Base Station Block Diagram	22
Chapter 5: Software	25
Connecting the PC to the Radio	25
Using the Appropriate Software Program	26
Receiver and Transmitter Programming	30
Firmware Version Number	33
CI-RC-4M Multiple Link Controller Programming.....	34
Chapter 6: Radio System Components	37
Daniels P25 Radio System Components.....	37
Subrack.....	38
System Monitor	43
Power Amplifiers	45
Tuning and Maintenance Tools	45



CHAPTER 1: INTRODUCTION

This document is written as an introduction to Daniels Electronics Ltd. MT-4R and MT-4D P25 Digital and Analog Radio Systems. The document assumes the reader is familiar with conventional Two-Way Radio Communications systems.

Project 25 is a standards initiative, to be amended, revised and added to as the users identify issues and as experience is gained.

DANIELS MODEL NUMBERS

Daniels Electronics Ltd. has manufactured radio systems for more than 60 years. In the early years, Daniels manufactured AM and SSB radiotelephones for the marine industry, and more recently, the MT series of radios for mountain top repeaters and base station applications.

MT-2

The MT-2 series of radio modules were originally manufactured in the 1980s. This radio series was a crystal controlled analog radio system capable of wideband (25 KHz) operation. Although systems are still in operation throughout North America, this series of radio modules was discontinued in the 1990s and is no longer supported.

MT-3

The MT-3 series of radio modules were originally manufactured in the early 1990s. This radio series was available with both crystal controlled and synthesized analog radio modules capable of wideband (25 KHz) or narrowband (12.5 KHz) operation. The MT-3 radio modules were discontinued in 2006, with the exception of the VHF Lowband and AM products. For more information on the MT-3 series of radios, see the Daniels MT-3 Analog Radio Systems User Guide.

MT-4

The MT-4 series of radio modules entered production during 2001. This radio series is the P25 compliant digital narrowband radio system, capable of analog (wideband and narrowband) or P25 digital operation.

Daniels Electronics is committed to continually improving and enhancing our product line. As the MT-4 P25 products evolve, the hardware, firmware and software of the radio modules change. In order to define these changes, the MT-4 product line is further described as:

MT-4R

The MT-4R series of P25 radios were manufactured from 2001 until the end of 2003.

MT-4D

The MT-4D series of P25 radios were manufactured from 2003 until the middle of 2006.

MT-4E

The MT-4E series are the current line of Analog and P25 modules.

DIFFERENCES BETWEEN MT-4R AND MT-4D SERIES MODULES

The MT-4R and MT-4D modules are basically identical in operation, with some advancements taking place in the RSS software programming for the MT-4D (such as the ability to software program the squelch tail on/off and timer). The only significant difference between the MT-4R and MT-4D is in the transmitter modules. The MT-4R transmitter was not capable of being programmed for mixed mode operation. Mixed mode is the ability for one transmitter channel to operate on either analog or digital, based on the received signal. In order to simulate mixed mode, the MT-4R transmitter was programmed with Bank A as the analog channels and Bank B as the digital channels, and the received signal simply switched between Bank A and B. The MT-4D is capable of mixed mode, so Bank A and B can be programmed in either analog or digital operation.

A P25 system can be comprised of both MT-4R and MT-4D modules. For example; an MT-4R receiver and MT-4D transmitter can be used to create a repeater, or an MT-4D link pair can be added to an MT-4R repeater.

REPEATER AND BASE MODULES

Daniels MT-4D product line is separated into base and repeater modules. There is different hardware, firmware and software for the base and repeater modules. MT-4R modules are all repeater modules, so no distinction between base and repeater is made. MT-4D modules are referred to as either MT-4D Repeater modules or MT-4D Base modules.

The MT-4D Repeater modules are capable of being connected in a repeater configuration or a base station configuration with no encrypting / decrypting capability (clear mode). MT-4D Base modules must be used when encryption capability (secure mode) in a base station configuration is required. MT-4D Base modules have limited repeat capability using analog audio paths. The analog audio repeat path does not pass all digital information through the repeater (such as NAC, TGID, encryption and data packets).

IDENTIFYING MT-4 MODEL NUMBERS

Being able to identify the series of MT-4R or MT-4D P25 module that you have is critical for programming, and understanding capabilities and operation of the equipment. The model number of the P25 receiver or transmitter module can be found on the bottom of the front panel of the receiver or transmitter module as shown in Figure 1-1. Figure 1-2 and 1-3 show the breakdown of the receiver and transmitter model numbers.

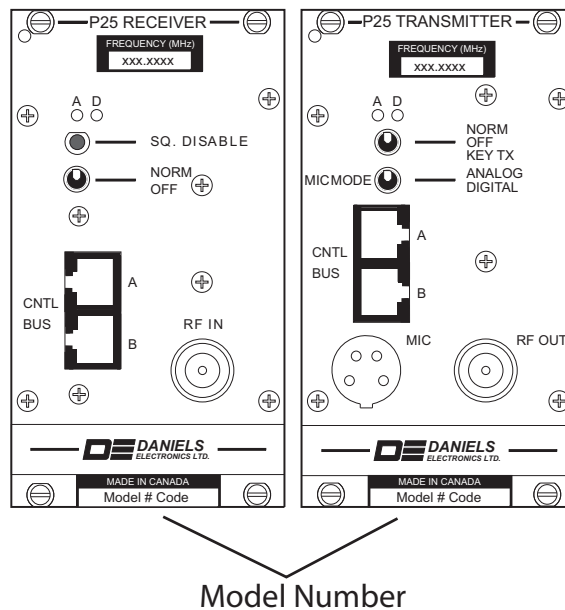

Figure 1-1: Model Number Location

MT-4R & MT-4D P25 RECEIVERS

EXAMPLE: UR-4D420-R0-000

MT-4 UHF P25 Receiver, MT-4D series, (406-430 MHz), Repeater functionality, no added options

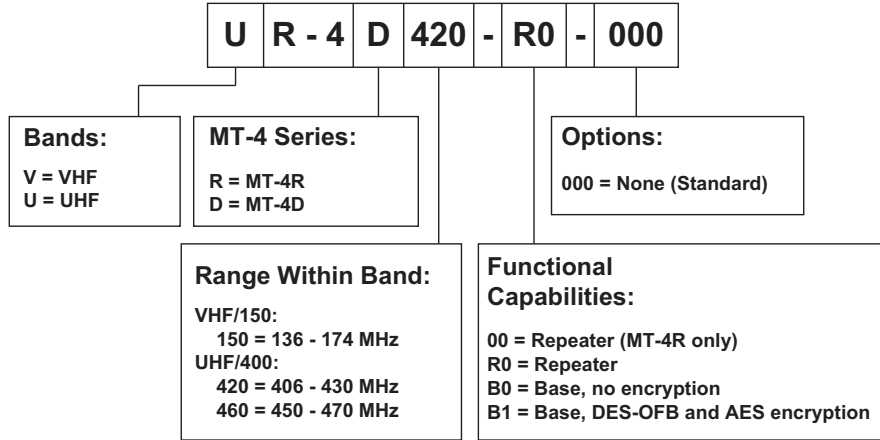

Figure 1-2: Receiver Model Numbers

MT-4R & MT-4D P25 TRANSMITTERS

EXAMPLE: VT-4D160-B0-800

MT-4 VHF P25 Transmitter, MT-4D series, (150-174 MHz), Base functionality (no encryption), 8 Watts, no added options

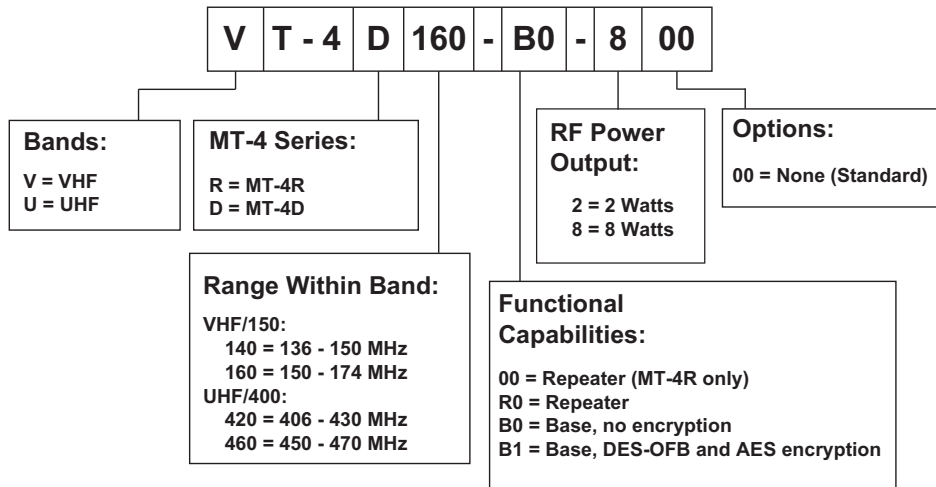

Figure 1-3: Transmitter Model Numbers

HARDWARE, FIRMWARE AND SOFTWARE DEFINITIONS

Hardware

The hardware is the radio module itself. Daniels P25 Receiver module hardware is comprised of a front end filter, an RF board (comprised of a local oscillator, mixer and demodulator), and DSP and controller boards and audio circuitry. Daniels P25 Transmitter module hardware is comprised of the audio circuitry, DSP and controller boards, RF board (modulator), and RF amplifier. The hardware for the different MT-4 series is slightly different, using different chipsets in the MT-4R, and MT-4D series, as well as differences for base and repeater modules.

Firmware

The firmware is the programming that is contained within the radio module. The firmware resides within the DSP and controller boards and is programmed at the Daniels factory. The RSS programming software can read the firmware version number of MT-4D modules. The RSS programming software for the MT-4R modules is not capable of reading the firmware version.

Software

The Radio Service Software or RSS is used to program features and options. The RSS programs RF frequencies, modes of operation (analog, digital or mixed mode), CTCSS, NAC codes, etc. The RSS connects to a radio module using an adapter between the serial port on a computer and the RJ45 interface on the front panel of the radio module. There are different RSS versions for the different series of modules as well as for base and repeater modules.

AVAILABLE FREQUENCY BANDS

The MT-4R and MT-4D modules were available in the VHF (136 - 174 MHz) and UHF (406 - 430 MHz and 450 - 470 MHz) frequency bands.



CHAPTER 2: TECHNICAL INFORMATION

FRONT PANEL RJ45 CONNECTOR JACKS

Daniels MT-4R and MT-4D Radio Equipment uses RJ45 jacks on the Receiver, Transmitter and controller cards. These jacks have several different uses, depending on the model series and configuration of the equipment. The receivers and transmitters each have two separate jacks that are connected in parallel to signal lines inside of the module. The jacks are labeled A and B and are identical.

On the MT-4R and MT-4D Repeater modules, the jacks are used to connect the Receiver to the controller and the controller to the Transmitter through RJ45 interconnection cables. The interconnection cables carry Low Voltage Differential Signaling (LVDS) serial data as well as analog and digital COR and PTT signals. The RJ45 interconnection cables are specific to Daniels Electronics equipment. Do not use Ethernet or other manufacturers cables.

On the MT-4D Base modules, the jacks are used to connect to a Motorola® KVL3000 or KVL3000 PLUS key loader, to load encryption keys in the Receiver and Transmitter encryption modules. This connection uses a custom Daniels cable from the key loader to our radio.

On all MT-4R and MT-4D Receiver and Transmitter modules, the RJ45 jacks are also used to connect the Daniels RSS programming software. Daniels custom Radio Programming Interface Module (RPIM) allows the serial port of a computer to communicate with the receiver or transmitter for RSS programming.

LVDS SERIAL DATA

Daniels MT-4R and MT-4D Repeater modules use Low Voltage Differential Signaling (LVDS) serial data to communicate between receiver, controller and transmitter modules. MT-4D Base modules do not use LVDS serial data.

A conventional analog repeater uses analog audio to communicate between the different modules. Daniels P25 radio systems use serial data between modules to allow for a completely transparent digital path between the modules. This means that all digital information is passed through the repeater system quickly and completely intact.

When a Daniels P25 Receiver receives a P25 digital transmission, the receiver samples the incoming information and then creates an LVDS serial data stream (of 257.8 kbps) that contains the same information as the Common Air Interface (with some overhead data). When a Daniels P25 Receiver receives an analog transmission, the receiver samples the incoming information and then creates a serial data stream (of 257.8 kbps) of the analog information. The incoming frequency and deviation is converted to serial data through an A/D converter. The transmitter uses this information to recreate the P25 digital or analog transmission.

DANIELS P25 DATA PACKET REPEATING (OTAR, GPS, ETC.)

The P25 Common Air Interface (over the air signaling) supports Voice Messages and Data Packet Units (confirmed or unconfirmed data messages). Data Packet Units support Over The Air Rekeying (for encrypted systems), GPS position information, and other data applications.

Daniels P25 MT-4D repeater modules are capable of repeating the P25 Data Packet Units. The MT-4D receiver and transmitter modules must have firmware version 2.0 or higher to properly repeat Data Packet Units. MT-4R modules are not capable of repeating Data Packet Units.

MIXED MODE OPERATION

Mixed mode operation is used to allow the receivers and transmitters to work in either analog or P25 digital mode without reprogramming the radio.

A mixed mode receiver will receive the incoming FM or C4FM transmission and will automatically detect and demodulate the signal to an analog or P25 digital signal. The receiver will then output either an analog or digital COR signal, as well as the appropriate serial data. A mixed mode transmitter will accept the incoming serial data and analog or digital PTT and will modulate the signal as either FM or C4FM, based on its input. This allows the repeater to repeat both analog and P25 digital signals.

The MT-4R and earlier MT-4D modules mixed mode response times are slightly delayed compared to analog only mode or P25 digital only mode. MT-4D modules with firmware version 2.0 or higher now have the same response times in mixed mode as in analog only mode or P25 digital only mode.

UPGRADING FIRMWARE VERSIONS

Daniels MT-4R modules must be returned to the factory for firmware upgrades. The last firmware version for MT-4R modules is Version 3.3 for the Transmitter and Version 3.8 for the Receiver. Previous firmware versions can be returned to the factory for upgrade.

The MT-4D Base modules must be returned to the factory for firmware upgrades.

The MT-4D Repeater modules may be returned to the factory for firmware upgrades. An MT-4D Repeater Firmware Upgrade Kit is also available for loan from Daniels Service department. Contact the factory for availability of the firmware upgrade kit.

Table 2-1 shows the firmware versions for MT-4 modules.

Table 2-1: Firmware Versions

MT-4R Receiver

Version	Description / Notes
Earlier than 3.7	Return to factory for upgrade
3.7	Last release until December 2005 (version 3.8)
3.8	Bug fix for CTCSS lockup

MT-4R Transmitter

Version	Description / Notes
Earlier than 3.3	Return to factory for upgrade
3.3	Last release

MT-4D Receiver (Repeater)

Version	Description / Notes
1.0	Initial product release
1.1	Minor factory bug fixes
2.0	Faster COR response time Capable of passing data packet units intact (OTAR, etc.)
2.1	Modification to speed up CI-RC-4M Response time
2.2	Bug fix for CTCSS lockup

MT-4D Transmitter (Repeater)

Version	Description / Notes
1.0	Initial product release
1.1	Transmit LED bug fix (LED was slow to light)
1.2	Transmitter lock-up bug fixed (Tx locks when keyed while powering up)
2.0	Faster PTT response time Capable of passing data packet units intact (OTAR, etc.)
2.1	Bug fix for hardware problem in new circuit board revision
2.2	Modification to speed up CI-RC-4M response time
2.3	Bug fix for lockup condition Added courtesy tone

MT-4D Receiver (Base)

Version	Description / Notes
1.0	Initial product release
1.1	Faster COR response time Bug fixes for squelch override, and secure/clear output Analog / Digital audio levels equalized
1.2	Bug fix for CTCSS lockup

MT-4D Transmitter (Base)

Version	Description / Notes
1.0	Initial product release (Beta version)
1.1	Initial product release (Faster PTT response time than Beta)
1.2	Secure/clear output bug fix

REPEATING DIGITAL SIGNALS

A P25 digital signal is received and retransmitted by the repeater completely intact. The digital codes such as TGID, Source ID, Destination ID, Algorithm ID, Key ID, etc. all pass transparently through the repeater system.

The TGID and Unit ID programmed into the transmitter are normally overwritten with the incoming TGID and Source ID when the transmitter is used in a repeater. The TGID and Unit ID are only transmitted when the transmitter is keyed in a non-repeater mode (no input from the receiver) or in a repeating mode using the analog audio repeat path (where all digital information is stripped off from the receiver). A non-repeater mode would include keying by the front panel microphone or base station keying (from a tone remote, etc.).

The Network Access Code (NAC) does not normally pass transparently through the repeater. NAC codes are similar to analog CTCSS tones. The NAC is typically programmed into the receiver and transmitter independently, allowing the user to program different receive and transmit NAC codes. To pass the NAC code through the repeater transparently, program the receiver with the special NAC code \$F7F. This will allow any incoming NAC code to unquiet the receiver and will overwrite the NAC code programmed into the transmitter with the incoming NAC code, allowing transparent operation.

Status Symbols are not passed through the repeater transparently. Status Symbols are changed by the repeater to indicate inbound channel status (busy). In Base Station mode the Status Symbols are set to show unknown status of the inbound channel. Status Symbols are not programmable.

Talk Groups are typically used in subscriber units, but a repeater could also be programmed as part of a Talk Group. The receiver can be programmed to unquiet on a specific NAC and TGID.

If the receiver is programmed for use in a Talk Group, the NAC code of that receiver must not be set to \$F7E or \$F7F, as the NAC code unquiet will take precedence over the TGID and the receiver will unquiet on any incoming NAC code (ignoring the TGID programmed setting).

Encrypted (AES or DES-OFB) voice signals will pass transparently through the repeater. Since the signal is encrypted, the analog audio output from the receiver will be "garbled". The System Monitor speaker can be used to monitor the audio output; but the encrypted signal will be unintelligible.

For a more detailed explanation of the P25 protocol, signaling and terminology, please see Daniels P25 Training Guide.



CHAPTER 3: P25 RADIO SYSTEM CONFIGURATIONS

REPEATER OPERATION

The **MT-4R** and **MT-4D Repeater** modules may be configured to operate as a repeater, a repeater with a link, a cross-band system or two independent repeaters using the **CI-RC-4L** repeater control card. The repeater system can be set for analog only, P25 digital only, or mixed mode operation. In mixed mode, the receiver determines the incoming signal (analog or digital) and transmits the same signal.

The receiver and transmitter modules connect to the CI-RC-4L repeater controller through RJ45 cables as shown in Figure 3-1.

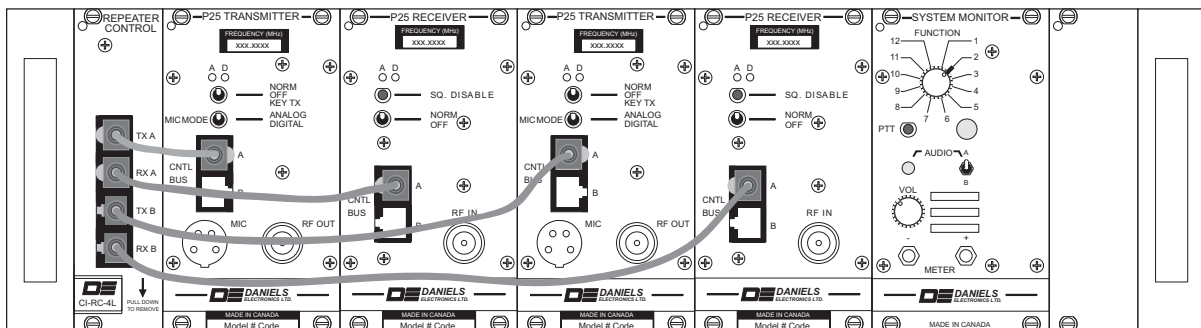

Figure 3-1: P25 Repeater System shown with two pairs of transceivers

The repeater controller is hardware jumpered to control the interconnection between the modules. This allows the user to select the operation of this system (single repeater, dual repeater, repeater with link, cross-band system, etc.) by setting jumpers. Receiver priority and simplex operation can also be jumpered for certain configurations.

The RJ45 cables carry the signals from the receiver, through the controller to the transmitter(s). The signals on the RJ45 cables are analog COR/PTT, digital COR/PTT and LVDS serial data. The LVDS serial data is the digitized analog or P25 digital information that is passed through the repeater. Analog audio is not passed through the RJ45 cables. The cables connect to either the A or B ports on the front of the receiver and transmitter modules. The A and B ports are identical (the signals are in parallel). The two ports allow the user to program the radio modules (the programming cable plugs into the same ports), without removing the RJ45 jacks that are connected for operation.

COMPLEX REPEATER OPERATION

The **MT-4R** and **MT-4D Repeater** modules may be configured to operate in complex repeater configurations of up to four sets of transceivers using the **CI-RC-4M** multiple link controller.

The receiver and transmitter modules connect to the **CI-RC-4M** repeater controller through RJ45 cables connected to the front panel of the transmitter and receiver modules. The **CI-RC-4M** repeater controller is a 1RU height controller that is installed separately from the radio subrack as shown in Figure 3-2.

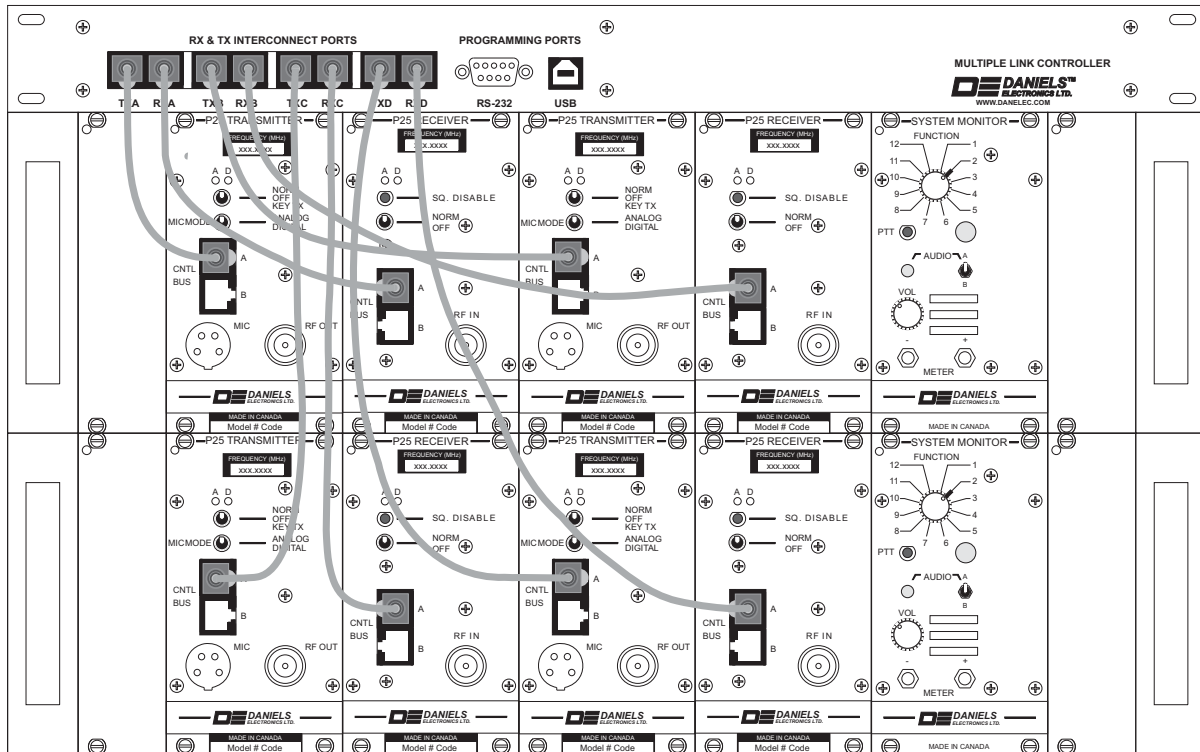

Figure 3-2: P25 Repeater System shown with four pairs of transceivers

The **CI-RC-4M** repeater controller is software programmable to allow flexible programming options for the radio system. The **CI-RC-4M** controller provides the following features:

- interconnection of up to four receiver and four transmitter modules in any configuration (repeater, repeater with links, cross-band systems, etc.).
- multiple CTCSS tones and NAC codes may be selected to operate each connection between receivers and transmitters (up to seven CTCSS/NAC for each link).
- DTMF control of receiver to transmitter links.
- setting of receiver priorities.
- transmitter channel switching based on received CTCSS or NAC.
- auxiliary E&M connections.
- four independent general purpose outputs that can be controlled by NAC, CTCSS or DTMF (open collector 750 mA / 30 Vdc max).

REPEATER OPERATION WITH EXTERNAL ANALOG WIRELINE CONTROL

The **MT-4R** and **MT-4D Repeater** modules have a 600 ohm balanced input / output for use with analog audio. The receiver modules also have a parallel analog audio output that is used to drive the speaker built in to the System Monitor module. To connect the analog audio from the receiver / transmitter modules to an external device (such as a tone remote adapter), the analog audio is routed through a **CI-BC-4E** base controller.

The RJ45 cables are connected directly from the receiver to the transmitter for the repeat path, and all external analog audio, COR and PTT routing is through the base controller auxiliary inputs and outputs. Figure 3-3 shows a P25 repeater system configured for wireline control.

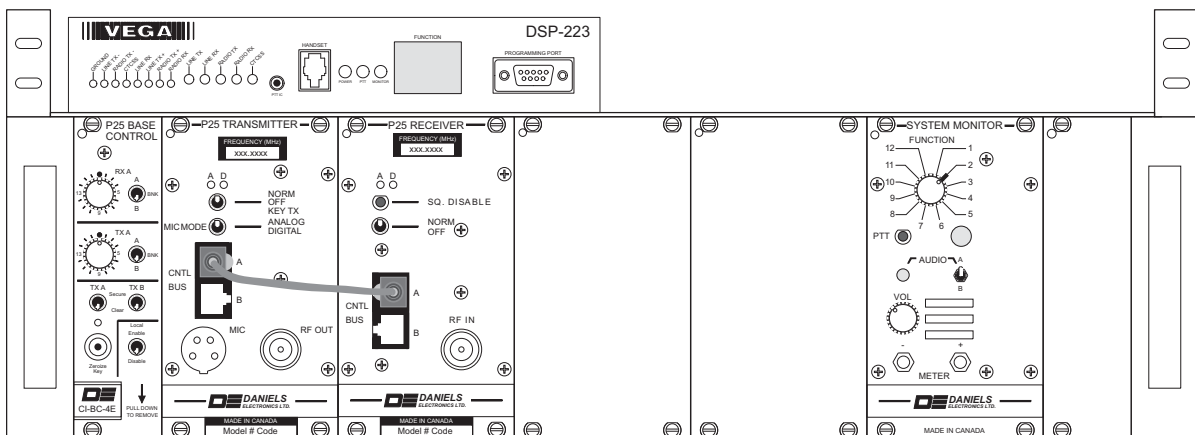

Figure 3-3: P25 Repeater System with Wireline Control shown with Repeater modules

The Vega DSP-223 tone-remote adapter provides the means of remotely controlling Daniels Electronics base stations and repeaters. The adapters can be used in conjunction with tone-remote control consoles which use the industry-standard sequential tone keying format. The DSP-223 adapters are interconnected to the distant remote control console(s) by any analog voice grade transmission medium such as a microwave link, a leased telephone line, or a twisted-pair 600-ohm line.

Alternate Configuration (Using Analog Audio)

Optionally, the user could set the repeat path through the base controller, and disconnect the RJ45 cable repeat path. The repeat path through the controller uses analog audio (not serial data as the RJ45 cables use). The analog audio repeat path is slower than the RJ45 path, and does not pass all digital information through the repeater (such as NAC, TGID, encryption and data packets).

This alternate configuration of using analog audio as the repeat path will work with the **MT-4R**, **MT-4D Base** modules and the **MT-4D Repeater** modules.

ANALOG CONTROLLED BASE STATION OPERATION

Daniels P25 Analog Controlled Base Stations can be operated in encrypted or clear modes.

Encryption Mode Configuration

Encryption mode requires the **MT-4D Base** modules. The MT-4D Base modules may have optional DES-OFB or AES encryption modules installed in the receiver and transmitter. The MT-4D Base modules are used with a **CI-BC-4E** base controller in order to properly connect the analog audio from the receiver / transmitter modules to an external device (such as a tone remote adapter). The base controller also has the ability to clear the encryption keys in the receiver and transmitter through a “Zeroize Key” button on the front of the base controller. No other module has the capability to zeroize encryption keys.

Figure 3-4 shows a P25 base station with MT-4D Base modules. The MT-4D Base modules must be used in the encryption mode configuration, as they are the only radio modules capable of having the optional encryption / decryption modules installed in them.

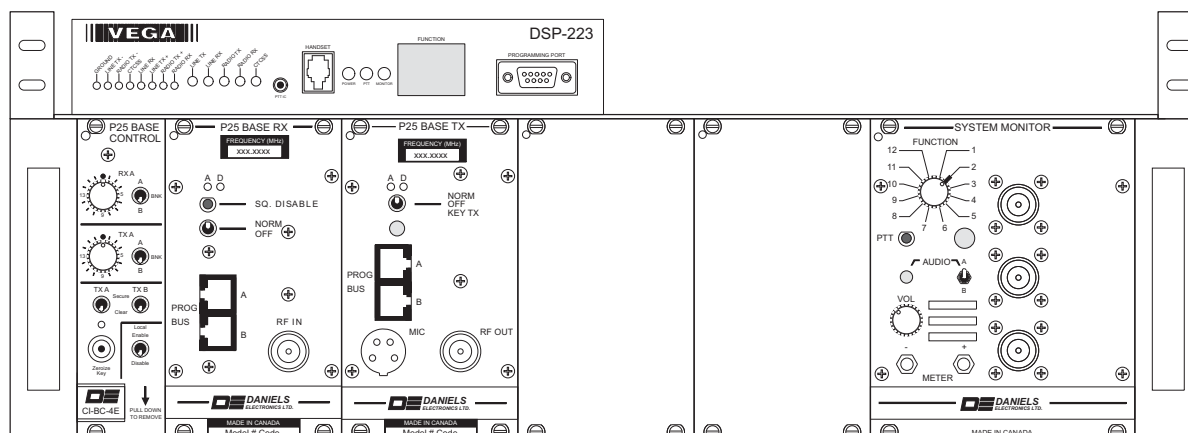

Figure 3-4: Encryption Mode P25 Analog Controlled Base Station shown with Base modules

Clear Mode Configuration

In Clear Mode either the **MT-4D Base** or **MT-4D Repeater** modules may be used. The MT-4D Base or Repeater modules are used with a **CI-BC-4E** base controller. This allows the analog audio from the receiver / transmitter modules to be connected to an external device (such as a tone remote adapter).

Figure 3-5 shows a P25 base station with MT-4D Repeater modules. If the encryption mode configuration is not required, the MT-4D Base or MT-4D repeater modules may be used for this clear mode configuration base station.

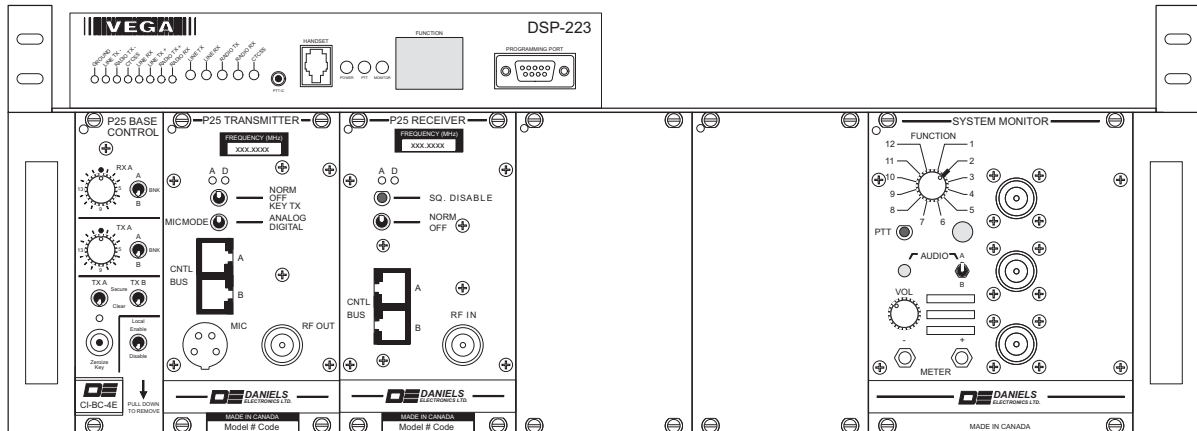

Figure 3-5: Clear Mode P25 Analog Controlled Base Station shown with Repeater modules

The MT-4D Base or MT-4D Repeater modules used in a base station configuration may also be configured as a clear mode base station with repeat capability. See Repeater Operation with External Analog Wireline Control section for more information.

FIXED STATION ETHERNET INTERFACE OPERATION

The **MT-4R**, **MT-4D Repeater** and **MT-4D Base** modules may be configured to operate as a digital Ethernet controlled base station using the **UIC-4-00** Universal Interface Card (UIC). The UIC card provides a direct digital interface from the receiver and transmitter to an IP network via an RJ45 Ethernet connector. The UIC allows the Ethernet interface to and from both MT-3 and MT-4 receiver and transmitter modules. This Ethernet interface allows digital signals (such as NAC, TGID, Source ID) to be passed through the network to and from web based applications and digital consoles. Figure 3-6 shows the UIC card used in the fixed station Ethernet interface system.

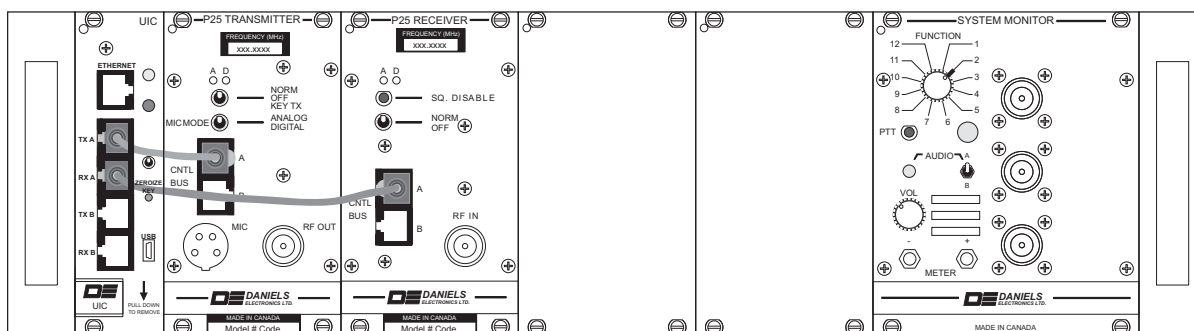

Figure 3-6: Fixed Station P25 Digital Ethernet Interface

Several releases of the UIC card firmware are planned. The first two releases are outlined below:

Release 1.0

The UIC card uses PCM based audio and a proprietary signaling format that Daniels Electronics Ltd. makes available to any console / VoIP manufacturers that may wish to be compatible with Daniels base stations. Daniels is currently working with **Catalyst Communications Technologies**, **Twisted Pair Solutions**, **Avtec**, and **Pantel** in support of this open interface.

Features:

- Receive / Transmit baseband PCM audio via UDP protocol over Ethernet
- Flash upgradable firmware
- Channel and Bank control
- Ability to identify incoming P25 NAC

Release 2.0 (Available First Quarter 2007)

The UIC card is TIA-102.BAHA Conventional Fixed Station Interface compliant. Daniels is currently working with **Telex/Vega Signalling Products** and **Zetron** in support of this P25 interface.

Features:

- Receive / Transmit IMBE vocoded audio via RTP protocol over Ethernet
- Encryption capability from the console (end-to-end encryption)
- Multiple console support
- Ability to identify incoming P25 Unit (Source) ID, Talk Group ID and Emergency bit



CHAPTER 4: P25 SYSTEM BLOCK DIAGRAMS

This chapter contains sample block diagrams of P25 mixed mode repeater and base station systems. These blocks are shown to give a basic understanding of the signal flow through a Daniels repeater or base station. Although mixed mode systems are shown, analog only or P25 digital only can be programmed in the receiver or transmitter.

REPEATER BLOCK DIAGRAM

Figure 4-1 shows a block diagram of a Daniels P25 mixed mode repeater system using a CI-RC-4L or CI-RC-4M repeater controller.

The incoming FM or C4FM transmission is routed through the Front End sub-module where the RF signal is filtered (high selectivity multiple pole, helical resonator filter, 5 MHz pass band VHF, 7 MHz pass band UHF) amplified through a low noise amplifier and then passed on to the RF Board which performs the conversion to the first IF, crystal filtering of the first IF, conversion to the second IF, digital filtering of the first IF, and demodulated to two quadrature-related baseband outputs. The baseband output is converted into a digitally sampled signal and is routed to the DSP circuitry where it is automatically detected as an analog or P25 digital signal and is then routed through either the analog or P25 digital settings programmed into the receiver. Analog signal settings may include CTCSS or DCS decoding, de-emphasis and wide or narrowband selection. P25 digital settings will include NAC and/or TGID decoding. The digitally sampled analog or P25 digital signal is then split and routed out of the receiver as both LVDS serial data out the front panel, and analog audio out the subrack / motherboard. If a P25 digital signal is sent out as analog audio, the signal must first be de-vocoded before it can be converted to analog audio. An analog or digital COR signal is also routed out the front panel.

The analog and digital COR signals and LVDS serial data are then routed through the repeater controller (CI-RC-4L Repeater Controller or CI-RC-4M Multiple Link Controller) and are sent to the transmitter as analog and digital PTT signals and LVDS serial data.

The transmitter will accept the incoming LVDS serial data and route it through the analog or P25 digital settings programmed into the transmitter. Analog signal settings may include CTCSS or DCS encoding, pre-emphasis and wide or narrowband selection. P25 digital settings will include NAC encoding (unless the receiver is set to a NAC of \$F7F to pass the NAC through the repeater). The digitally sampled analog or P25 digital signal is then converted back to a baseband signal and is then modulated as either an FM or C4FM transmission based on the analog or digital PTT input. The modulated carrier is then amplified by the RF Power Amplifier sub-module. The analog audio input to the transmitter is not used in a repeater configuration.

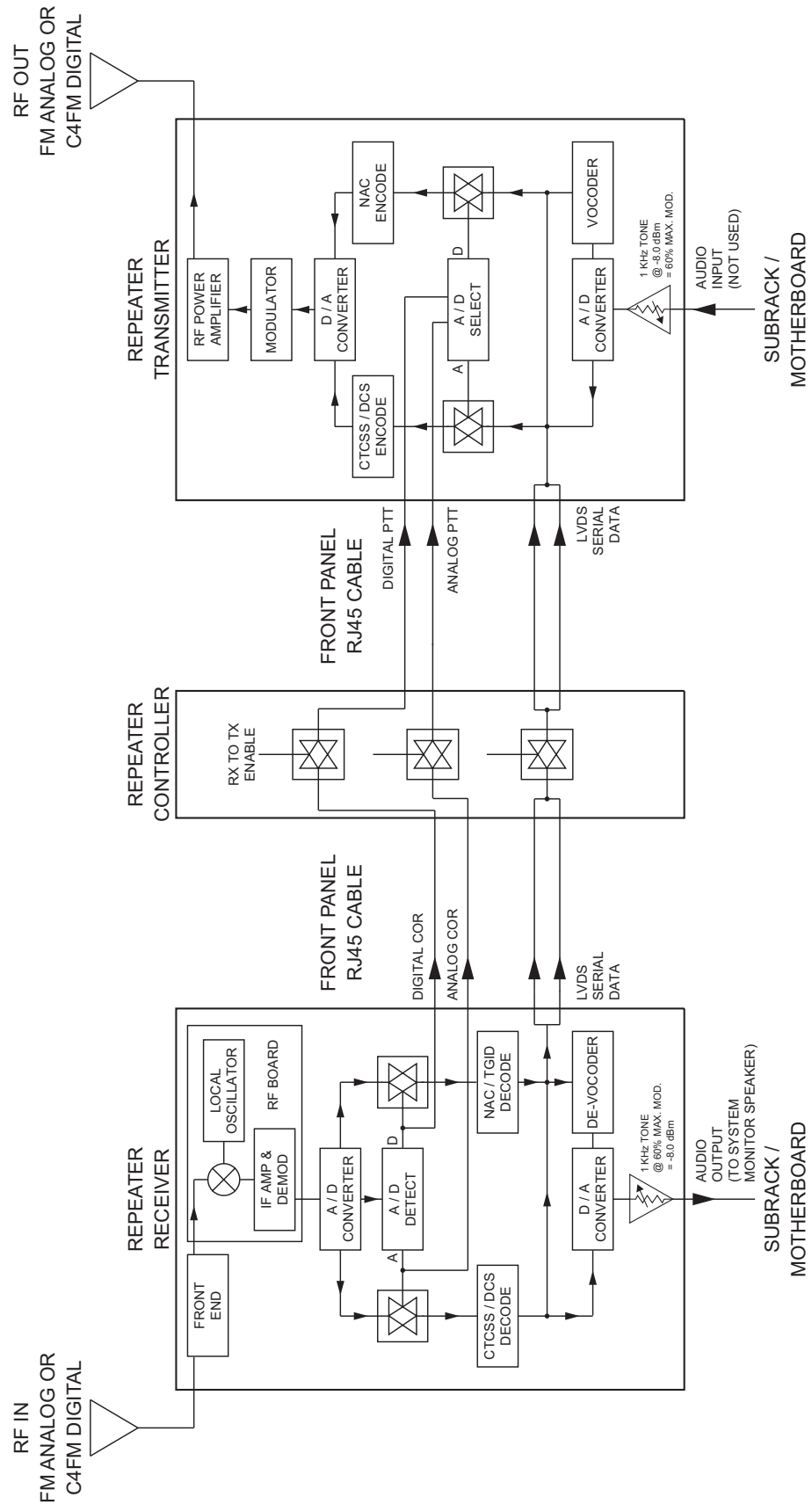

Figure 4-1: P25 Repeater Block Diagram

BASE STATION BLOCK DIAGRAM

Figure 4-2 shows a block diagram of a Daniels P25 analog controlled base station system using a CI-BC-4E base controller.

The incoming FM or C4FM transmission is routed through the Front End sub-module where the RF signal is filtered (high selectivity multiple pole, helical resonator filter, 5 MHz pass band VHF, 7 MHz pass band UHF) amplified through a low noise amplifier and then passed on to the RF Board which performs the conversion to the first IF, crystal filtering of the first IF, conversion to the second IF, digital filtering of the first IF, and demodulated to two quadrature-related baseband outputs. The baseband output is converted into a digitally sampled signal and is routed to the DSP circuitry where it is automatically detected as an analog or P25 digital signal and is then routed through either the analog or P25 digital settings programmed into the receiver. Analog signal settings may include CTCSS or DCS decoding, de-emphasis and wide or narrowband selection. P25 digital settings will include NAC and/or TGID decoding. The digitally sampled signal is then converted back to baseband and then routed out of the receiver as analog audio out the subrack / motherboard to the base controller. If a P25 digital signal is sent out as baseband analog audio, the signal must first be de-vocoded before it can be converted to baseband analog audio. MT-4D Base receivers may have an optional AES or DES-OFB decryptor module.

The analog audio is then routed through the base controller (CI-BC-4E Base Controller) and is sent to the auxiliary audio output for connection to an external device such as a tone remote adapter. The auxiliary audio input from the external device is routed through the base controller and is sent to the transmitter. Internal audio levels between the receiver, base controller and transmitter are typically set at -8.0 dBm for 60% of maximum modulation. Independent audio level controls in the base controller allow the auxiliary input and output levels to be adjusted separately (default is 0 dBm for 60% maximum modulation). For external control, the CI-BC-4E also has optically isolated COR and PTT inputs and outputs for connecting external equipment with high voltage control signals such as E&M.

The transmitter will accept the incoming analog audio, convert it to a digitally sampled signal, and then route it through the analog or P25 digital settings programmed into the transmitter. Analog signal settings may include CTCSS or DCS encoding, pre-emphasis and wide or narrowband selection. P25 digital settings will include NAC, TGID and Unit/Source ID encoding. MT-4D Base transmitters may have an optional AES or DES-OFB encryptor module. The signal is then converted back to a baseband signal and is then modulated as either an FM or C4FM transmission based on the analog or digital software settings, or the front panel switch. The modulated carrier is then amplified by the RF Power Amplifier sub-module.

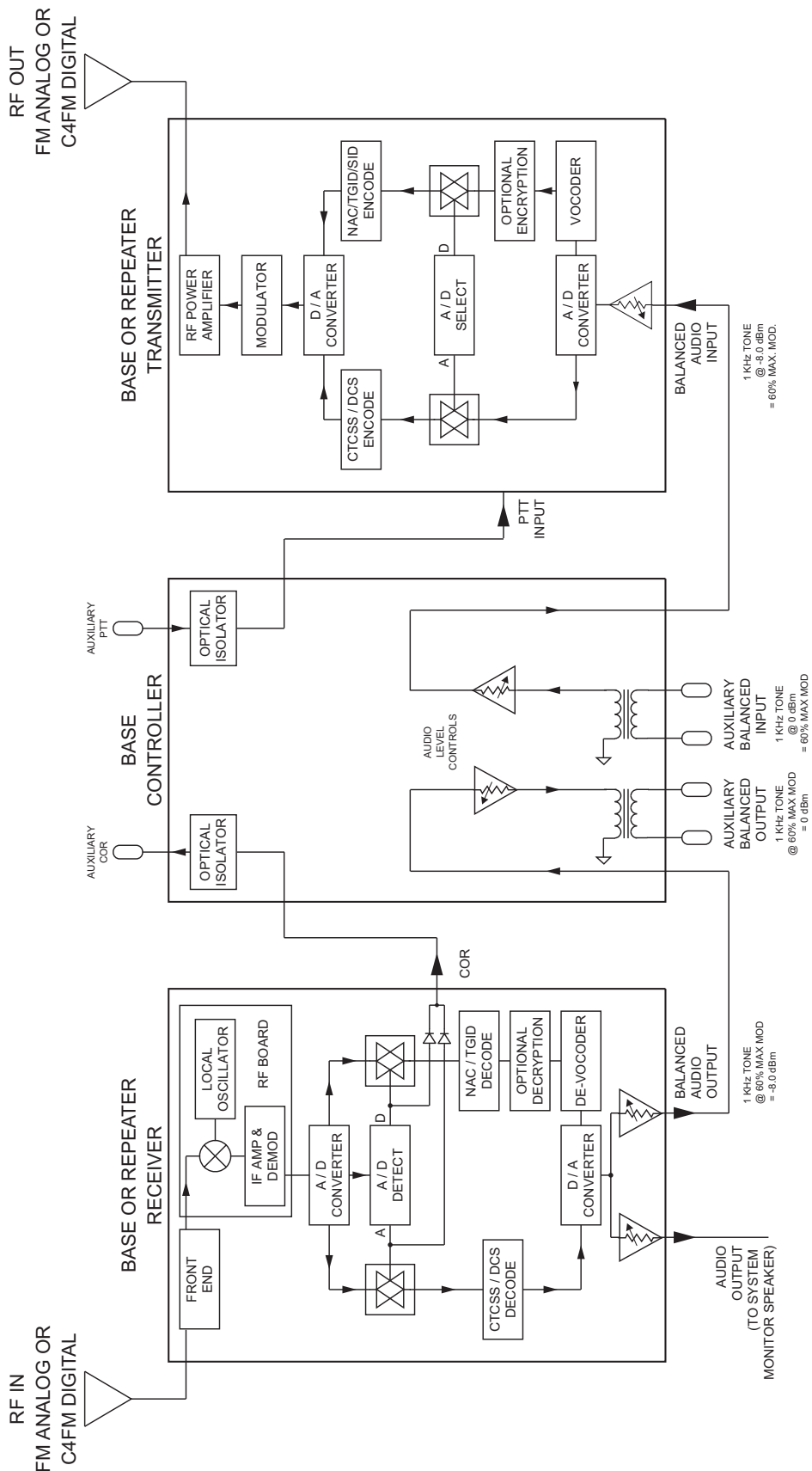

Figure 4-2: P25 Base Station Block Diagram



CHAPTER 5: SOFTWARE

CONNECTING THE PC TO THE RADIO

The RSS programming software will run on a PC with a Windows 95, 98, ME, 2000, NT, or XP operating system. The computer's serial port is connected to either the Receiver or Transmitter front panel RJ45 jack through a Daniels Radio Programming Interface Module (RPIM), as shown in Figure 5-1.

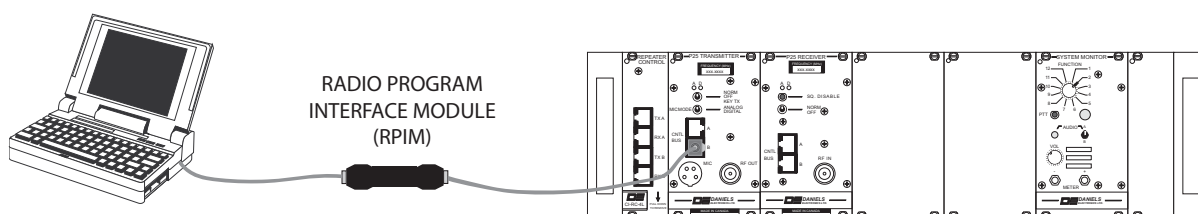

Figure 5-1: PC to Radio RSS software connection

The RSS may display a run-time error and fail to communicate with the module when used with some USB to serial adapters. Table 5-1 shows USB to serial adapters that have been successfully tested for compatibility with Daniels RSS software.

Table 5-1: USB to Serial Adapter Compatibility

Manufacturer	Part No.
Access I/O Products Inc.	USB-232
Sewell	SW-1301
BAFO Technologies	BF-810
ATEN Technology, Inc.	UC232A
BELKIN Corporation	F5U109
GoldX Products Inc.	GXMU-1200

USING THE APPROPRIATE SOFTWARE PROGRAM

Depending on the Receiver or Transmitter series (MT-4R; MT-4D Repeater; MT-4D Base), the appropriate software version must be used to program the module.

RSS for MT-4R modules

The **MT-4R** modules work with the program labeled **RSS** on your PC.

The RSS software disc is shown in Figure 5-2.



Figure 5-2: RSS software disc

The opening screen is shown in Figure 5-3.



Figure 5-3: RSS Program Example

RSS4D-R for MT-4D Repeater Modules

The **MT-4D Repeater** modules work with the program labeled **RSS4D-R** on your PC.

The RSS software discs are shown in Figure 5-4 (one of the two depending on the ship date):



Figure 5-4: RSS4D Repeater software discs

The opening screen is shown in Figure 5-5.

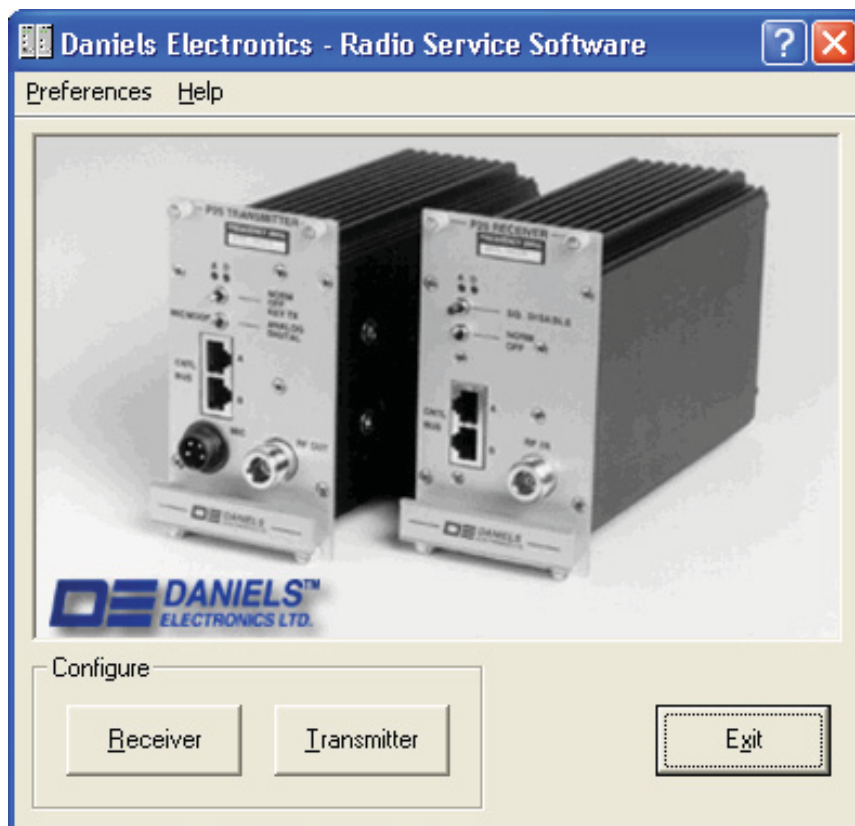

Figure 5-5: RSS4D-R Program Example

RSS4D-BASE for MT-4D Base Modules

The **MT-4D Base** modules work with the program labeled **RSS4D-BASE** on your PC.

The RSS software disc is shown in Figure 5-6.

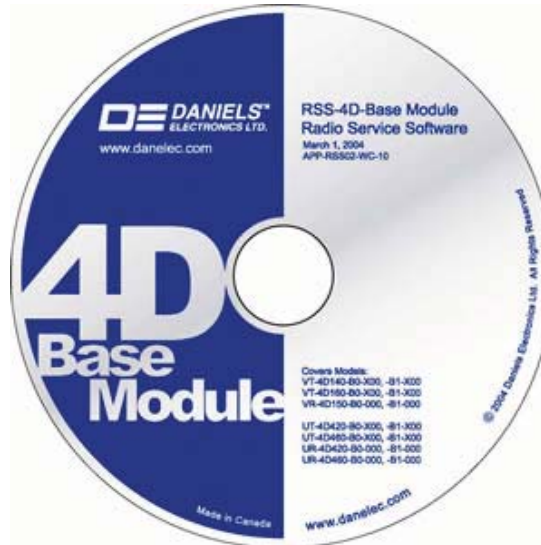

Figure 5-6: RSS4D Base software disc

The opening screen is shown in Figure 5-7.



Figure 5-7: RSS4D-BASE Program Example

RSS Version Number

The Version number of the RSS software can be found by clicking on Help – About in the main title screen. An example of this screen is shown in Figure 5-8.



Figure 5-8 RSS Version Number Example

RECEIVER AND TRANSMITTER PROGRAMMING

The RSS programs the Receiver and Transmitter modules independently. The programming cable must be connected to the module being programmed. Figure 5-1 shows an example of this connection.

The MT-4D Repeater Receiver programming screen is shown in Figure 5-9.

Figure 5-9: MT-4D Repeater Receiver Program Example

The MT-4D Repeater Transmitter programming screen is shown in Figure 5-10.

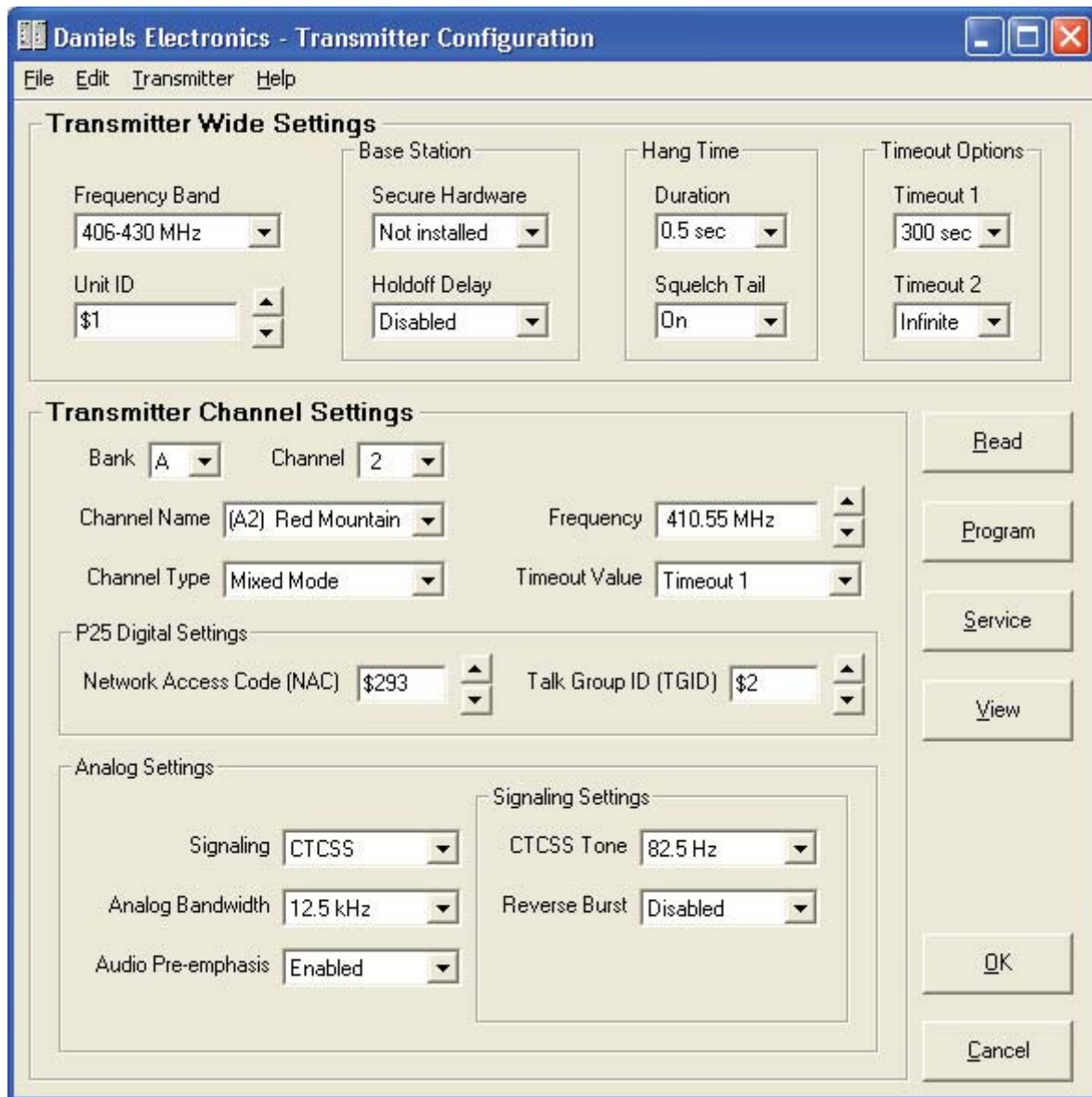
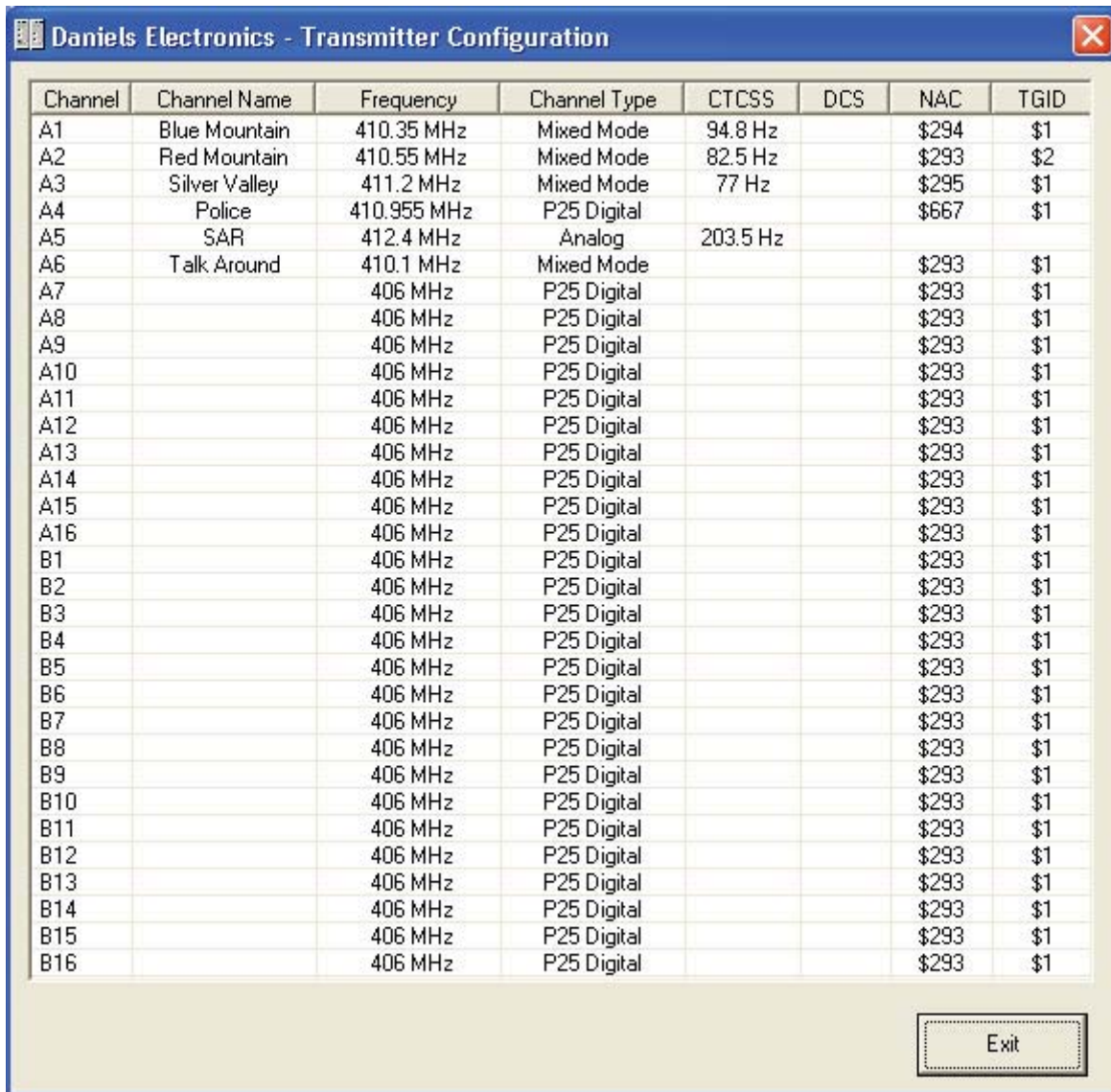

Figure 5-10: MT-4D Repeater Transmitter Program Example

A View All screen can be opened to look at all of the programmed frequencies, tones, codes, etc in one window.

The Transmitter View All screen is shown in Figure 5-11.



Channel	Channel Name	Frequency	Channel Type	CTCSS	DCS	NAC	TGID
A1	Blue Mountain	410.35 MHz	Mixed Mode	94.8 Hz		\$294	\$1
A2	Red Mountain	410.55 MHz	Mixed Mode	82.5 Hz		\$293	\$2
A3	Silver Valley	411.2 MHz	Mixed Mode	77 Hz		\$295	\$1
A4	Police	410.955 MHz	P25 Digital			\$667	\$1
A5	SAR	412.4 MHz	Analog	203.5 Hz			
A6	Talk Around	410.1 MHz	Mixed Mode			\$293	\$1
A7		406 MHz	P25 Digital			\$293	\$1
A8		406 MHz	P25 Digital			\$293	\$1
A9		406 MHz	P25 Digital			\$293	\$1
A10		406 MHz	P25 Digital			\$293	\$1
A11		406 MHz	P25 Digital			\$293	\$1
A12		406 MHz	P25 Digital			\$293	\$1
A13		406 MHz	P25 Digital			\$293	\$1
A14		406 MHz	P25 Digital			\$293	\$1
A15		406 MHz	P25 Digital			\$293	\$1
A16		406 MHz	P25 Digital			\$293	\$1
B1		406 MHz	P25 Digital			\$293	\$1
B2		406 MHz	P25 Digital			\$293	\$1
B3		406 MHz	P25 Digital			\$293	\$1
B4		406 MHz	P25 Digital			\$293	\$1
B5		406 MHz	P25 Digital			\$293	\$1
B6		406 MHz	P25 Digital			\$293	\$1
B7		406 MHz	P25 Digital			\$293	\$1
B8		406 MHz	P25 Digital			\$293	\$1
B9		406 MHz	P25 Digital			\$293	\$1
B10		406 MHz	P25 Digital			\$293	\$1
B11		406 MHz	P25 Digital			\$293	\$1
B12		406 MHz	P25 Digital			\$293	\$1
B13		406 MHz	P25 Digital			\$293	\$1
B14		406 MHz	P25 Digital			\$293	\$1
B15		406 MHz	P25 Digital			\$293	\$1
B16		406 MHz	P25 Digital			\$293	\$1

Figure 5-11: View All Example

FIRMWARE VERSION NUMBER

Information on the Receiver or Transmitter serial number, firmware version, model number or User names can be found by clicking on Receiver – ID or Transmitter – ID in the Receiver or Transmitter configuration screen.

The Receiver ID screen is shown in Figure 5-12.

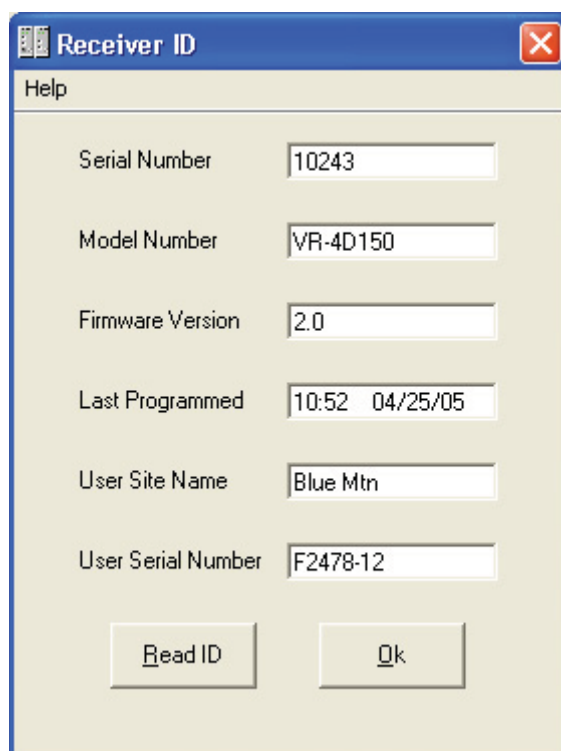

The image shows a software dialog box titled "Receiver ID". It has a standard Windows-style title bar with a close button (red X) in the top right corner. Below the title bar is a "Help" button. The main area of the dialog contains six text input fields, each with a label to its left:

- Serial Number: 10243
- Model Number: VR-4D150
- Firmware Version: 2.0
- Last Programmed: 10:52 04/25/05
- User Site Name: Blue Mtn
- User Serial Number: F2478-12

At the bottom of the dialog, there are two buttons: "Read ID" and "Ok".

Figure 5-12: Receiver ID Example

Note: The RSS program for MT-4R modules does not have the firmware version or user names in the ID window. Firmware versions can be found on the test sheets that came with the radio modules, or by contacting the factory.

CI-RC-4M MULTIPLE LINK CONTROLLER PROGRAMMING

The CI-RC-4M Multiple Link Controller is a software programmable controller. The Multiple Link Controller Software connects to the CI-RC-4M using the computers serial port through a standard serial or USB cable to the front panel of the controller.

The opening screen is shown in Figure 5-13.



Figure 5-13: CI-RC-4M Program Example

The configuration screen will allow for a wide variety of complex repeater configurations using a link configuration grid as shown in Figure 5-14. The grid uses color coding to indicate different connection settings.

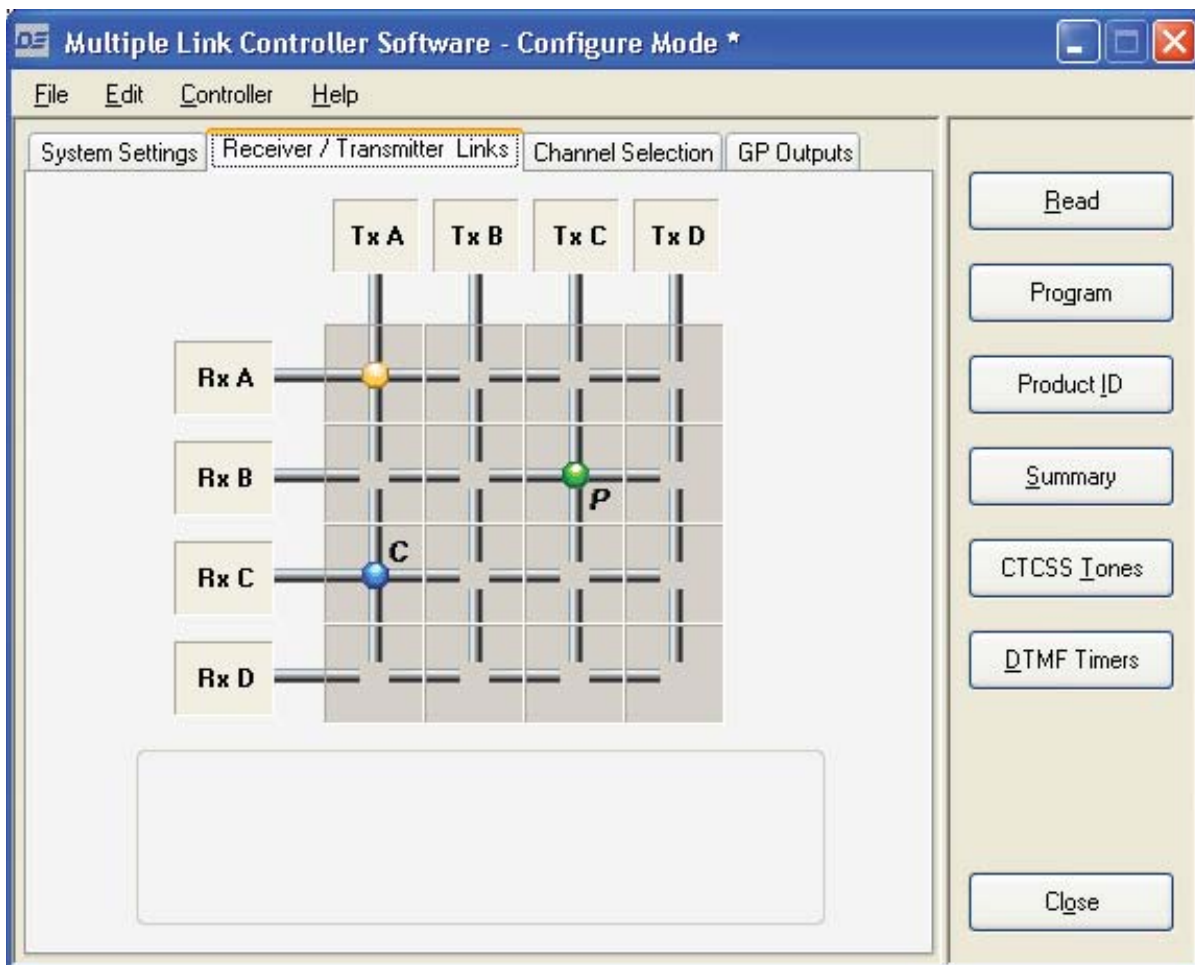
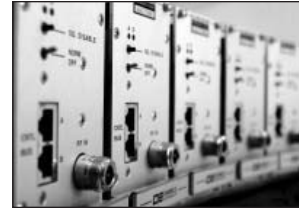

Figure 5-14: CI-RC-4M Program Link Configuration Grid



CHAPTER 6: RADIO SYSTEM COMPONENTS

DANIELS P25 RADIO SYSTEM COMPONENTS

A Daniels P25 Radio System consists of:

-
- P25 Receiver and Transmitter Modules (MT-4R, MT-4D Repeater, MT-4D Base, MT-4E)

 - P25 controller (CI-RC-4L, CI-RC-4M, CI-BC-4E)

 - RSS Software and Programming Interface Cable

 - Subrack (with Optional Auxiliary Connector)

 - System Monitor

 - Power Amplifiers

 - Tuning and Maintenance Tools

The Receiver, Transmitter, Controller, Software and Programming cable were discussed previously. The other radio system components are further explained in greater detail in this chapter.

All Daniels modules are hot swappable. There is no need to disconnect the power supply when inserting or removing the modules from the subrack. Most variable components are designed so that an increase in voltage, frequency, etc. is achieved by a clockwise turn, and a decrease is achieved by a counter-clockwise turn.

SUBRACK

The SR-39-1 subrack is designed to hold and interconnect the MT-4 series of P25 receiver, transmitter and control modules on one universal motherboard. The subrack has room for two receiver and transmitter pairs. The left side connectors are reserved for transmitter A and receiver A, while the right side connectors are reserved for transmitter B and receiver B. See Figure 6-1.

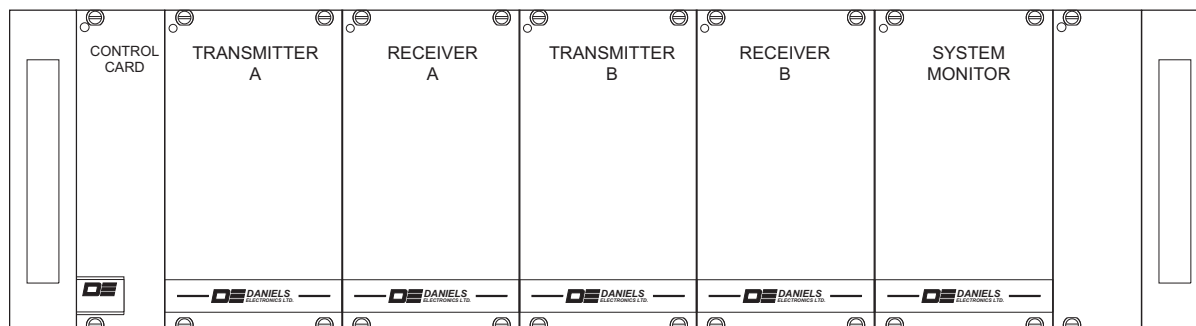

Figure 6-1: Standard Subrack Configuration

If a VHF or UHF 30 Watt power amplifier is installed, only one transmitter and receiver pair can be installed. The power amplifier takes up two slots as shown in Figure 6-2.

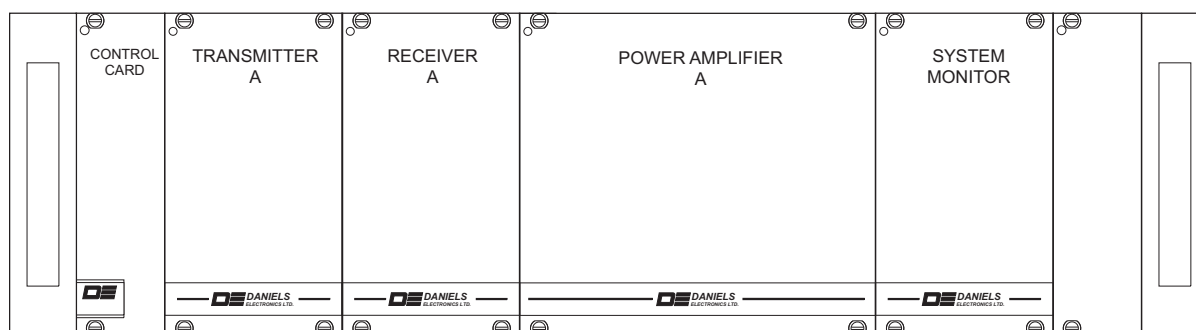

Figure 6-2: Standard Subrack with Power Amplifier

Power Input

The main power input (+10 to +17 Vdc; +13.8 Vdc nominal) connector is located on the back of the subrack, on the motherboard. There is an identical +9.5 Vdc power output connector on the motherboard that is used to power other Daniels equipment at +9.5 Vdc (the CI-RC-4M controller for example). Do not connect the main power input to the +9.5 Vdc power output connector, as a transient suppressor (over voltage protection) will short to ground to protect the equipment.

Reverse voltage protection and over voltage protection (transient suppressor) is provided at the main power input as well as the +9.5 Vdc line. The main power input is protected with a standard fast-blow 15 amp fuse. These components may require replacing if the power supply is not connected properly, or even after a power surge or a lightning strike. The two transient suppressors have different voltage ratings for the main power input and +9.5 Vdc lines. Figure 6-3 shows the subrack / motherboard rear view.

Channel Selection

Daniels P25 radio modules are capable of 16 channel operation in 2 banks (32 channels total). The 16 channels are controlled via 4 CSEL signal lines connected to each receiver and transmitter module. The CSEL signal lines are set as either a 0 (0 Vdc) or a 1 (+9.5 Vdc). Table 6-1 shows the channel selected for the CSEL input settings.

Table 6-1: Channel Selection Settings

Channel	Decimal	CSEL3	CSEL2	CSEL1	CSEL0
1	0	0	0	0	0
2	1	0	0	0	1
3	2	0	0	1	0
4	3	0	0	1	1
5	4	0	1	0	0
6	5	0	1	0	1
7	6	0	1	1	0
8	7	0	1	1	1
9	8	1	0	0	0
10	9	1	0	0	1
11	10	1	0	1	0
12	11	1	0	1	1
13	12	1	1	0	0
14	13	1	1	0	1
15	14	1	1	1	0
16	15	1	1	1	1

The Receiver and Transmitter Bank A/B select lines normally float high (+5V), selecting Bank A, but may be pulled low or high externally via the Bank A/B select line. The Receiver Bank A/B select line uses the same line as the MT-3 Receiver ISO COR K and the Transmitter Bank A/B select line uses the same line as the MT-3 Transmitter Standby.

There are 3 different ways to change the channel of a transmitter / receiver module:

- 1 The user can set jumpers mounted on the motherboard for each Channel Select signal line (Set of four for each Tx / Rx module). These jumpers can be used to permanently set a subrack slot at a specific channel.
 - Jumpers can be set for 0 (0 Vdc) “down” or 1 (9.5 Vdc) “up”
 - Pull-up resistor jumpers to 9.5 Vdc must be installed
 - These jumpers are read right to left (MSD to LSD)
- 2 CSEL signal lines can be controlled externally by a tone remote adapter, a CI-RC-4M multiple link controller, or other third party devices.
- 3 16 position rotary select switches mounted on the front of the base controller can control the CSEL lines, and optionally the CI-RC-4L repeater controller can have a rotary switch added.

The pull-up resistor jumpers to 9.5 Vdc must be removed and all channel select jumpers must be installed in the 1 or “up” position for both external control and rotary switch control of channel selection. The locations of the channel select and pull-up jumpers are shown in Figure 6-3.

Channel Switching Range

Although the receiver or transmitter channels can be programmed for any frequency in its band, the Maximum Switching Range of the module must not be exceeded or the module will require hardware re-tuning. The maximum switching range of the modules are listed in the Technical Notes, and are typically shown as +/- 1 MHz, +/- 2 MHz or Unlimited, based on the individual specifications of the module. For example, a VHF receiver may be programmed for any frequency between 136 to 174 MHz, but the front end helical filter has a typical pass band of 5 MHz, requiring re-tuning if two frequencies are used that are outside of that pass band.

Antenna Relay Activation

The motherboard on the subrack contains a set of jumpers that are used to activate the optional antenna relays in the System Monitor module. Figure 6-3 shows the location of these jumpers. The relays are typically set with the PTT and PTT OUT signal lines activating the relays.

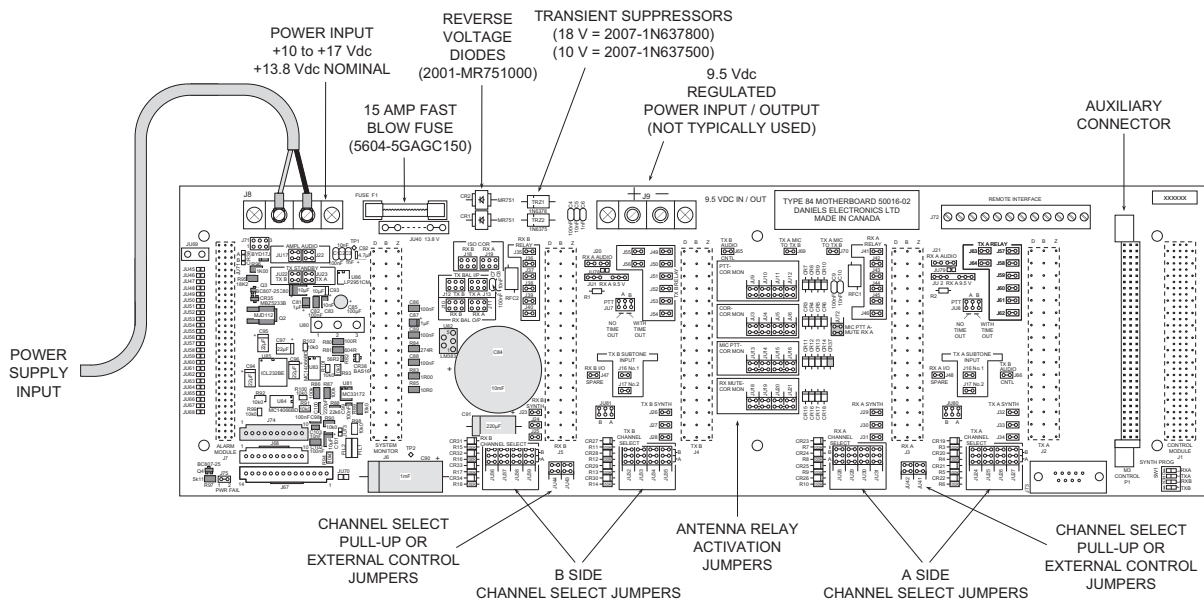

Figure 6-3: Subrack / Motherboard Rear View

Optional Auxiliary Connector

An optional component that can be added to the subrack is the A-PNL-AUX96-3 Auxiliary Connector. The auxiliary connector mounts on the back wrap-around cover of the subrack and connects to the auxiliary connector on the motherboard. The A-PNL-AUX96-3 brings all of the auxiliary connector signal lines out to screw terminals for easy connection. These connections are ideal for interfacing external equipment and allowing easy access for testing and tuning points. The A-PNL-AUX96-3 Auxiliary Connector and the back wrap-around cover are shown in Figure 6-4.

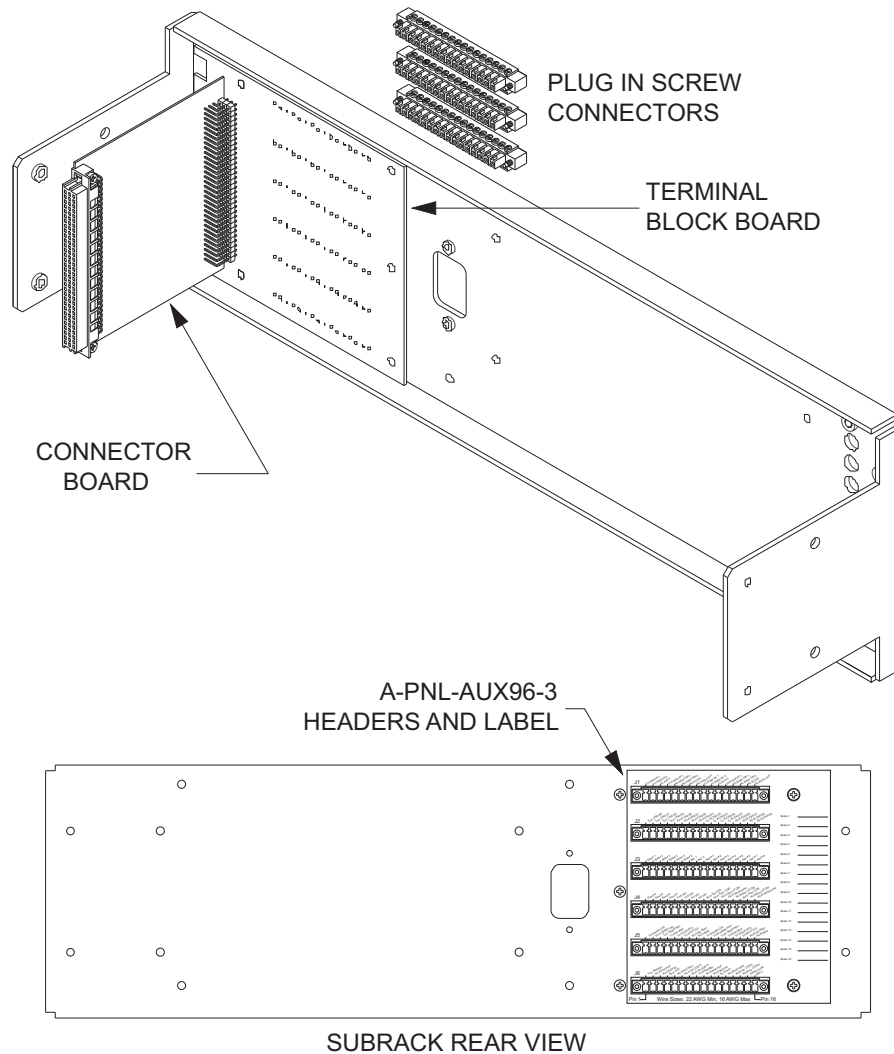

Figure 6-4: Auxiliary Panel Diagram

A close-up view of the auxiliary connector label, as shown in Figure 6-5, indicates the short signal name for each connection point. Definitions for these signals can be found in the SR-39-1 subrack manual. Extra connectors (Spare, Alarm, IMC) that can be used for different functions depending on the control card are listed to the right of the connectors. For example, the CI-BC-4E base controller uses these lines for auxiliary audio inputs / outputs and auxiliary COR / PTT connections. The custom functions of these connectors will be marked in the blank space next to the signal name.

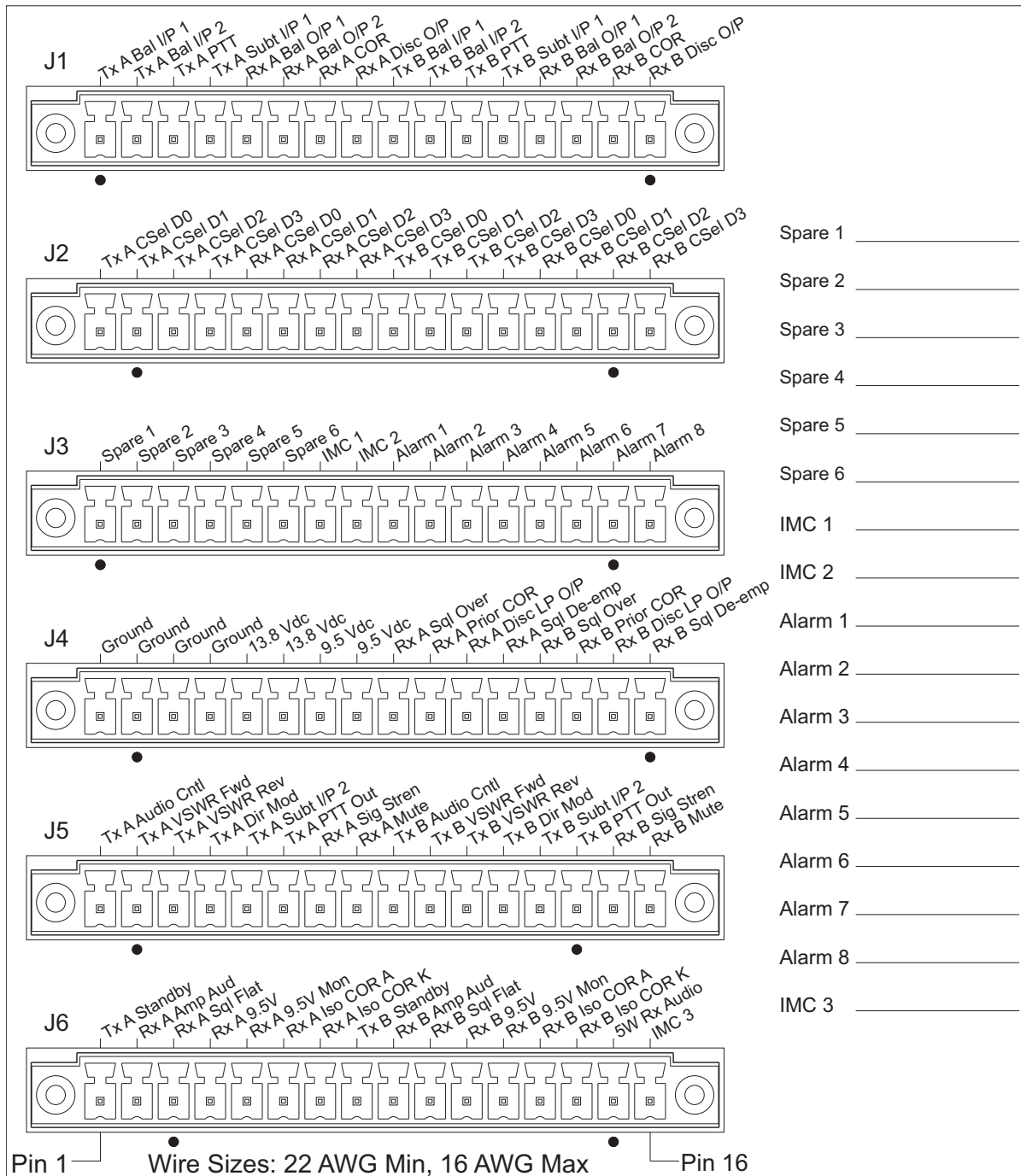

Figure 6-5: Auxiliary Panel Pin-Out

SYSTEM MONITOR

The SM-3 system monitor is a plug-in module which provides voltage regulation, system metering and audio monitoring for an MT-4 radio system. The SM-3 includes the following features:

- High current +9.5 Vdc voltage regulator with an anti-latchup hysteresis circuit.
- Front panel switch selectable meter outputs to check supply voltages, regulated voltages, etc.
- Audio amplifier and loudspeaker.
- Relay drivers for optional antenna relays.

There are several different models of System Monitors as shown in Figure 6-6. The basic SM-3 is the same size as a transmitter or receiver module. The System Monitor can also be purchased with 1 or 2 optional antenna relays.

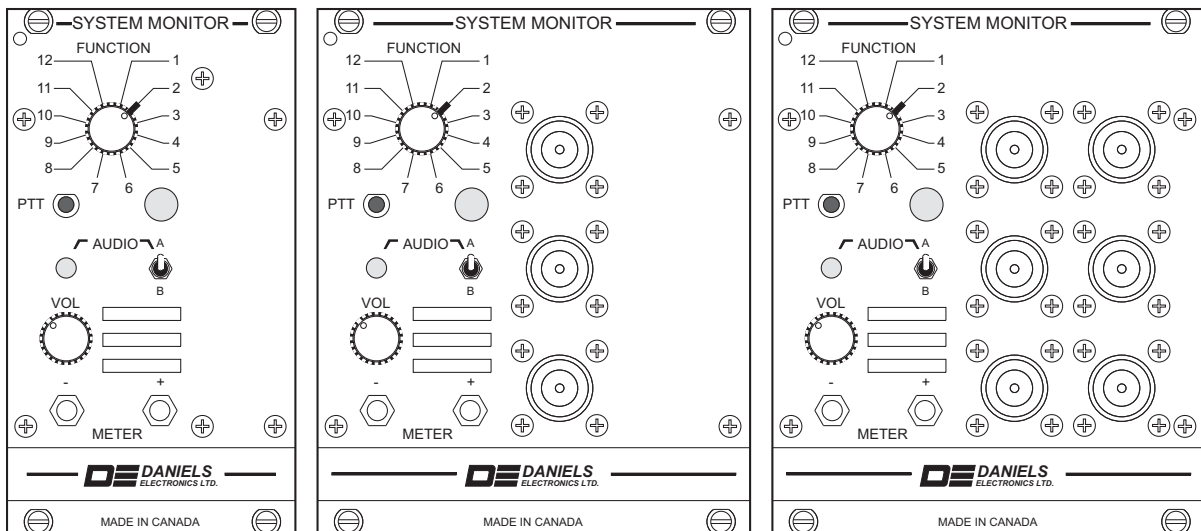

Figure 6-6: System Monitors

Simplex Operation

The System Monitor has an internal jumper that is enabled when the radio system is operated in simplex mode (simplex base station, or simplex links). The jumper connects the PTT OUT signal line to the RX MUTE. JU12 is enabled for the A side pair, and JU13 is enabled for the B side pair of receiver and transmitter. This jumper will cause the receiver to mute when the transmitter is keyed.

System Monitor Testing

The System Monitor module is designed with a convenient and easy test point built in to the front panel. This test point allows a technician access to the DC supply and regulated voltages. Simply connect a standard Digital Volt Meter (DVM) to the METER jacks on the front panel of the System Monitor as shown in Figure 6-7. Turn the rotary switch to the desired position to measure the supply voltage, regulated voltage or audio output as shown in Table 6-2. Note that the audio output requires a carrier and audio tone injected into the receiver.

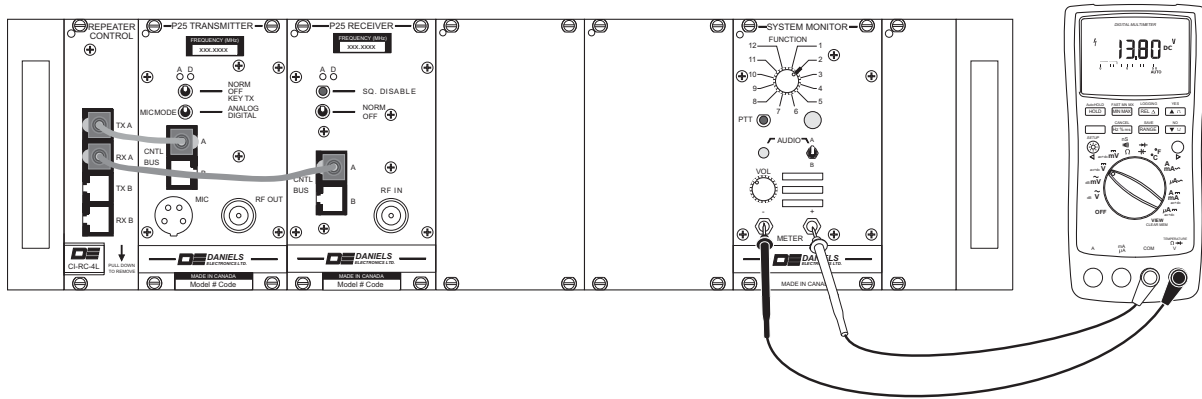

Figure 6-7: System Monitor Testing

Table 6-2: System Monitor Rotary Switch Functions

Position	Function	Parameter
2	Supply Voltage	+10 Vdc to +17 Vdc (+13.8 Vdc nominal)
3	+9.5 Volts Regulated	+9.5 Vdc (± 0.1 Vdc)
8	Rx A / B Audio	Receiver Audio (NOT Rx Balanced Output)

POWER AMPLIFIERS

The standard RF power output of the P25 transmitters is adjustable from 2 to 8 Watts. If a higher RF power output is required, the transmitter may be used as an exciter to drive a power amplifier. Daniels Electronics manufactures a 30 Watt power amplifier, shown in Figure 6-8, that will fit into a standard subrack.

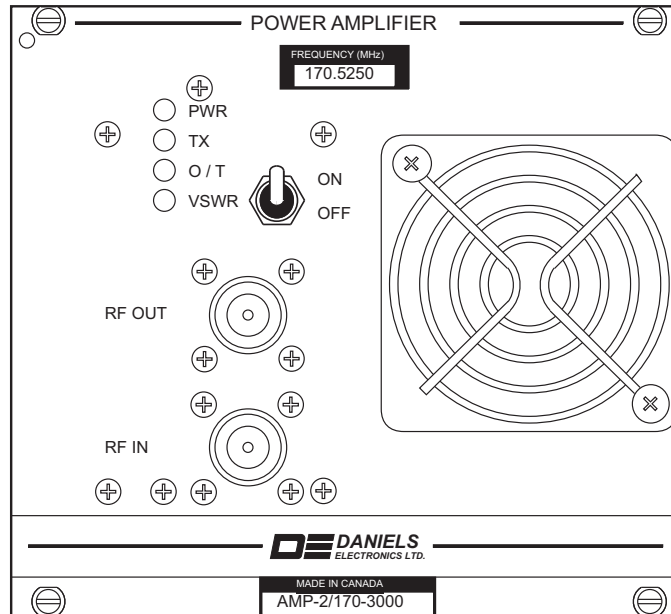

Figure 6-8: 30 Watt Power Amplifier

Daniels Electronics can also supply higher power amplifiers (60 W, 100 W, 250 W) that are 19" rack mountable. All transmitters and power amplifiers are rated for 100% continuous duty.

TUNING AND MAINTENANCE TOOLS

To facilitate testing, alignment and maintenance for the MT-4 radio systems, extender cards can be used to extend the individual modules out from the subrack. Extender kits (extender card plus a four foot cable) allow the modules to be extended out to a bench for servicing.

The following extender cards and kits are available:

EC-96D1 (direct connect) or **EC-96K-1.22** (card and cable)
Used for the 96 pin control cards (CI-RC-4L and CI-BC-4E).

EC-48RD (direct connect) or **EC-48RK-1.22** (card and cable)
Used for all receiver, transmitter, power amplifier and system monitor modules.

Figure 6-9 shows the 96 pin and 48 pin direct connect extender cards.

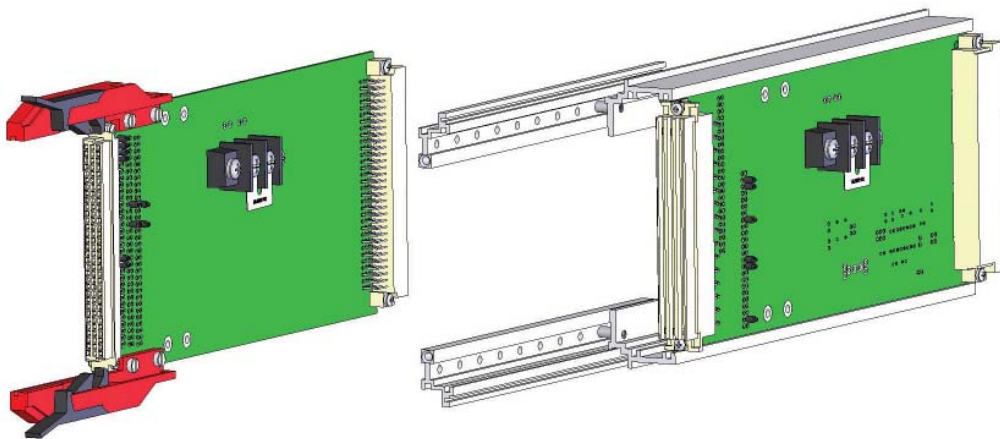

Figure 6-9: EC-96D1 and EC-48RD Direct Connect Extender Cards

The **A-TK-04** tool kit includes a number of spare parts for the MT-4 radio system, including tuning tools, guide rails, transient suppressors, diodes, a fuse, dust caps, shunt jumpers, ESD wrist strap, and various screws and hardware.

Daniels Electronics Ltd.
43 Erie Street, Victoria, BC
Canada, V8V 1P8
www.danelec.com
sales@danelec.com

Toll Free Canada and USA
Phone: 1-800-664-4066
Fax: 1-877-750-0004

International
Phone: 250-382-8268
Fax: 250-382-6139

©2011 Daniels Electronics Ltd. All Rights Reserved.

UG-001-4-0-0



www.danelec.com