



Appendix B: IFR COM-120 Test Procedures

MAINTENANCE GUIDE



Contents

Appendix B: IFR COM-120 Test Procedures	1
MT-4E Testing with the IFR COM-120 by Aeroflex.....	1
General Set-Up and Connections	2
Radio Service Software (RSS)	2
Control Cards	2
Turning OFF the MT-4E Receiver and Transmitter Modules	2
Adapters, Cables and Extender Cards	3
Audio Connections	3
Daniels MT-4E Radio System Test Sheet.....	3
System Regulator Testing	4
System Voltage Testing	4
Receiver Testing.....	5
Audio Distortion	6
Reference Sensitivity	7
Squelch.....	7
Audio Level	8
RF Preselector Alignment and Tuning	10
Reference Oscillator Adjustment	11
Transmitter Testing.....	14
Audio Distortion	16
RF Power.....	16
Reference Oscillator Adjustment	17
Deviation Level	18
CTCSS Testing	20
System Testing.....	22
Demodulated Audio Frequency	23
Distortion	23
Deviation Level	24



APPENDIX B: IFR COM-120 TEST PROCEDURES

MT-4E TESTING WITH THE IFR COM-120 BY AEROFLEX

This Chapter contains instructions for Tuning, Testing, Maintaining and Servicing MT-4E Analog and P25 Digital Radio Systems with the IFR COM-120 (B or C) by Aeroflex.

This Chapter is intended as an aid to configuring and testing Daniels MT-4E radios using an IFR COM-120 (B or C) Service Monitor by Aeroflex. Neither Daniels Electronics Ltd. or Aeroflex Inc. assume responsibility for damage caused to either unit as a result of misinterpretation or misuse of this procedure. Daniels manufactured products are warranted against defective materials and workmanship. This warranty does not extend to damage due to misuse, neglect, accident, improper configuration or installation. Daniels and Aeroflex shall be released from all obligations under its respective warranty in the event the Products are subject to misuse, neglect, alteration, accident, improper installation or testing, or if unauthorized repairs are performed by the customer or others.

These procedures can be modified, changed and altered at any time to better suit your specific needs and requirements. Refer to Daniels Electronics Instruction Manuals for complete radio system specifications.

GENERAL SET-UP AND CONNECTIONS

Radio Service Software (RSS)

Start the RSS program on the computer and ensure you are connected to the receiver or transmitter via the type A to 5 pin mini-type B USB cable. Read the transmitter or receiver programming and familiarize yourself with the settings (RF frequency, wide / narrowband, digital / analog, CTCSS / NAC, etc.).

Control Cards

Some Daniels MT-4E radio systems may have an AC-3E Audio Control Card or CI-BC-4E Base Control Card for use in the radio system. The Control Cards connect to the receiver and transmitter balanced audio lines with an unbalanced load, which could cause some measurements to be in error. If the radio system includes an AC-3E Audio Control Card or CI-BC-4E Base Control Card, remove the control card from the rack for the individual receiver and transmitter tests unless otherwise noted.

Turning OFF the MT-4E Receiver and Transmitter Modules

Turning the switch on the front panel of the MT-4E receiver or transmitter modules to the OFF position can cause unwanted effects on other MT-4E receiver and transmitter modules.

When the MT-4E receiver and transmitter are connected directly together with the LVDS serial data RJ45 cable, turning the MT-4E transmitter front panel switch to the OFF position will cause the MT-4E receiver module to turn off. The MT-4E receiver modules A and D LEDs on the front panel will blink on and off when this occurs. Turning the MT-4E receiver modules front panel switch to the OFF position will not cause any adverse effects on the MT-4E transmitter. When turning the MT-4E receiver modules front panel switch from the OFF to NORM position (or vice versa), it will cause the MT-4E transmitter to reboot. Remove the RJ45 cable to stop this interaction from occurring. When connecting the LVDS serial data RJ45 cables to the CI-RC-4L repeater control card or CI-RC-4M multiple link controller, the MT-4E receiver and transmitter modules are isolated from each other and the modules can be turned on or off independently of each other.

When the MT-4E receiver and transmitter channel and bank select lines are connected together in parallel, turning the MT-4E receiver or transmitter front panel switch to the OFF position will cause the channel and bank select lines to be grounded. This will cause the other MT-4E module to operate on Bank B, Channel 1 regardless of how the channel and bank select lines are set. If the bank select lines are not connected in parallel, only the channel will be affected. The channel select lines are independent of the LVDS serial data RJ45 cables (the cables will have no impact on the channel select).

When the MT-4E receiver and transmitter are connected to the antenna relay in the System Regulator module, turning the MT-4E transmitter front panel switch to the OFF position will cause the MT-4E transmitter PTT OUT line to be grounded, activating the antenna relay and causing it to be switched so that the transmitter is connected to the antenna. This makes it impossible to test the MT-4E receiver through the antenna relay when the MT-4E transmitter is turned off.

When performing maintenance on the Daniels MT-4E radio system it is best to simply remove the MT-4E receiver or transmitter, that is not being tested, from the subrack and disconnect all RJ45 cables, rather than turning the front panel switch to the OFF position. All Daniels modules are hot swappable. There is no need to disconnect the power supply when inserting or removing the modules from the subrack.

Adapters, Cables and Extender Cards

Various adapters, cables and extender cards are required for the different radio tests. Extender cards and adapters are available from Daniels Electronics. The receiver reference oscillator and RF preselector filter tests require an SMB - BNC adapter and a small SMB - SMB cable is required for the reference oscillator test as well. The SMB adapters and cables are included in the A-TK-04 Tool Kit

Audio Connections

The Receiver, Transmitter and Auxiliary Balanced audio lines are available for connection on Daniels extender cards or by connecting to the optional back panel A-PNL-AUX96-3 screw-type terminal connector. The extender cards have solder points available on each signal line that can have a small test point, (5059-TP110300) that is supplied with the extender card, soldered to them for easy connection with clip-on type clips. Recommended Test Points are:

Audio Control Card and Base Control Card Extender Card pins (EC-96D1 and EC-96K-1.22):

Auxiliary 1 Audio Output = B11 and A11

Auxiliary 2 Audio Output = C1 and C3 (Audio Control Card); C2 and C4 (Base Control Card)

Auxiliary 1 Audio Input = C19 and C20

Auxiliary 2 Audio Input = B14 and A14

Receiver and Transmitter Extender Card pins (EC-48RD and EC-48RK-1.22):

Rx Balanced Audio Output = B26 and Z26

Tx Balanced Audio Input = B18 and Z18

Tx Subtone Input = B22 and Ground (B32)

The test points can be soldered into the extender cards as shown in Figure B-1.

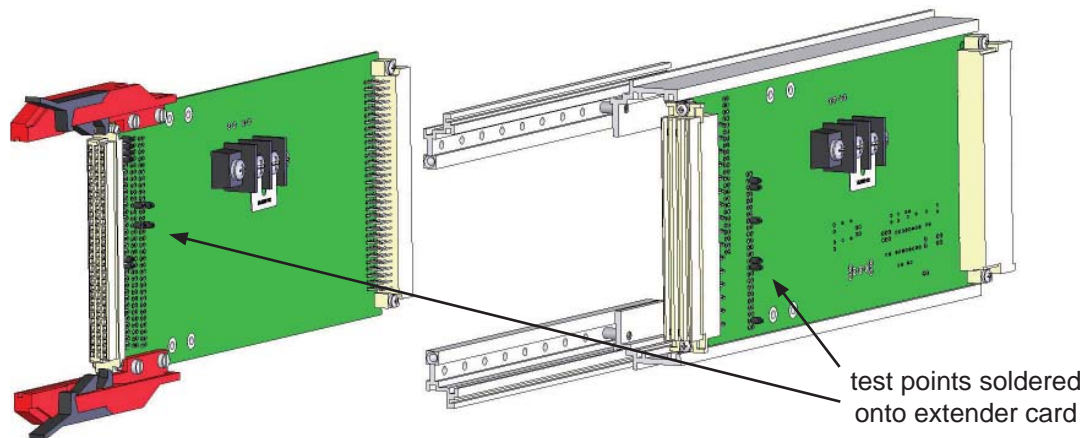

Figure B-1: EC-96D1 and EC-48RD Direct Connect Extender Cards with Test Points Added

Daniels MT-4E Radio System Test Sheet

A Daniels MT-4E Radio System Test Sheet is included in Chapter 7 of the Maintenance Guide. It is recommended that this test sheet be filled out each time the radio system is tested. If two or more pairs of transceivers are tested, use a second test sheet to record the results. The test sheet will record settings for a single Tx and Rx frequency, however other frequencies can be tested and recorded if desired.

SYSTEM REGULATOR TESTING

System Voltage Testing

The first stage of testing a Daniels MT-4E radio system is to perform a basic system check on the supply and regulated voltages. The System Regulator module is designed with a convenient and easy test point built into the front panel. This test point allows a technician access to the DC supply and regulated voltages. Simply connect a standard Digital Volt Meter (DVM) to the METER jacks on the front panel of the System Regulator as shown in Figure B-2.

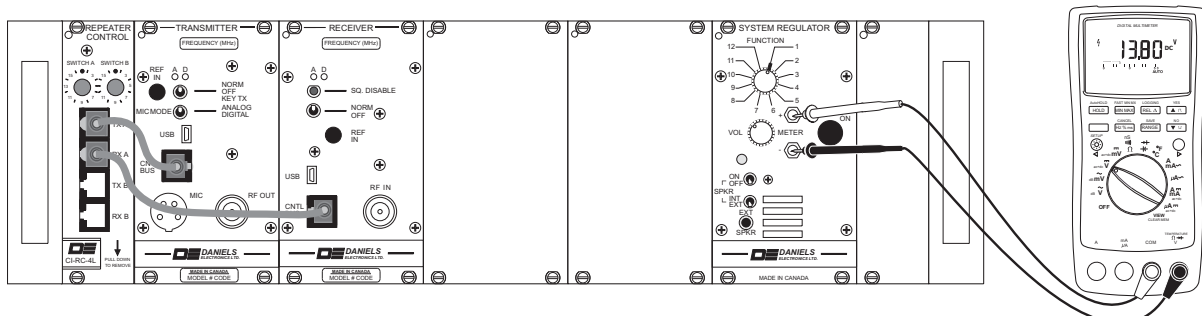

Figure B-2: System Regulator Voltage Testing

The FUNCTION rotary switch on the front panel of the System Regulator will allow you to test various points in the radio system. Following is a list of System Regulator rotary switch positions, the functions they measure and the parameters measured:

1	Supply Voltage	+10 Vdc to +17 Vdc (+13.8 Vdc nominal)
2	+9.5 Volts Regulated	+9.5 Vdc (± 0.1 Vdc)
3	Rx A Audio	Receiver A Audio (NOT Rx Balanced Output)
4	Rx A Carrier Strength	0 Vdc to +5.0 Vdc based on received signal strength (0 Vdc is a low RF signal level, +5.0 Vdc is high)
5	Rx B Audio	Receiver B Audio (NOT Rx Balanced Output)
6	Rx B Carrier Strength	0 Vdc to +5.0 Vdc based on received signal strength (0 Vdc is a low RF signal level, +5.0 Vdc is high)

Enter the Supply Voltage and +9.5 Volts Regulated values on the MT-4E Test Sheet and inject a -100 dBm carrier signal into the Receiver and record the RSSI Voltage on the MT-4E Test Sheet. Enter the Date, Firmware Versions and Serial numbers of the Receivers and Transmitters on the MT-4E Test Sheet. The Firmware Version and Serial Number can be found by connecting the RSS and clicking on Rx ID or Tx ID. The Serial Numbers can also be found on the side of the modules.

The standby current draw of the radio system should be measured for battery / solar powered systems. Connect an ammeter to the power input line and measure the standby current draw and transmit current draw of the system. Enter the Standby Current Draw and Transmit Current Draw readings on the MT-4E Test Sheet. The maximum standby and transmit current draw is dependent on the radio system (number and class of receivers, transmitter output power, amplifiers, auxiliary equipment, etc.).

RECEIVER TESTING

Connect the IFR COM-120 and Daniels Radio as shown in Figure B-3:

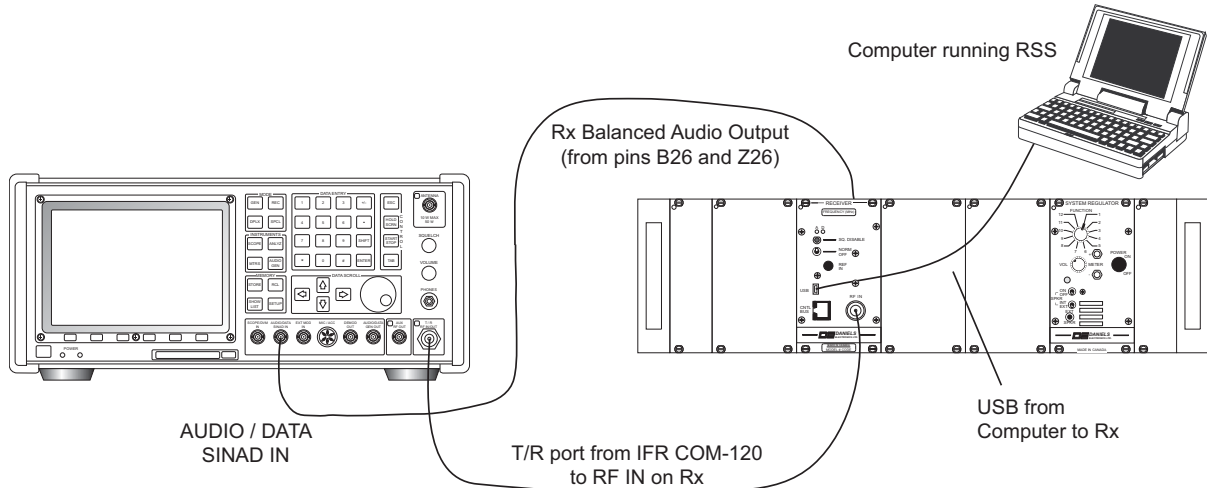

Figure B-3: Receiver Testing

Set up the IFR COM-120 as shown in Figure B-4.

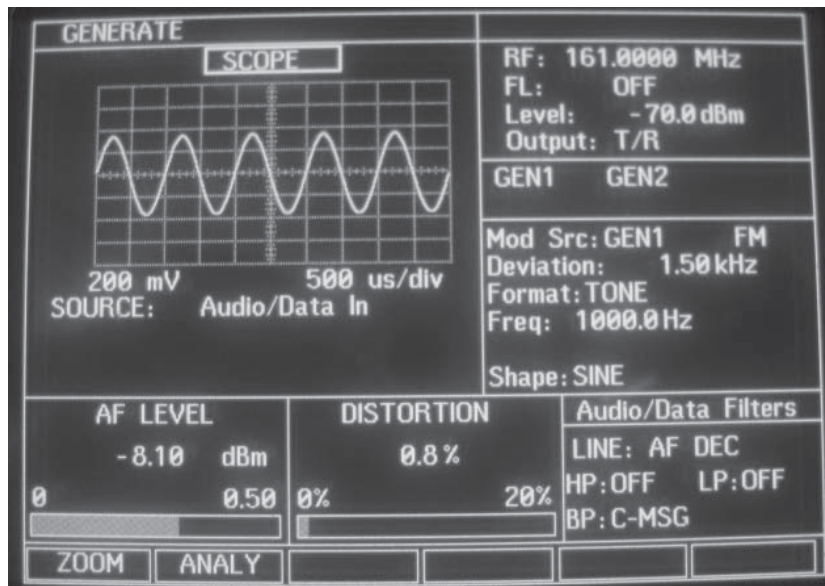

Figure B-4: Receiver Measurements

The AF LEVEL and SCOPE may not read as shown, these levels are set with an external 600 ohm matching load. Audio levels will read higher without the matching load. See the Receiver and Auxiliary Output Audio Level section for more information. Enter the correct RF frequency, and ensure that the deviation level is set at +/- 60% maximum deviation (+/- 1.5 KHz (narrowband) or +/- 3.0 KHz (wideband)).

To enter the correct CTCSS tone (if used) and deviation level for the tone, highlight Mod Src and select GEN2, then highlight OFF and select FM. Highlight Freq and enter the CTCSS decode tone, then highlight Deviation and enter a deviation of +/- 0.35 KHz (narrowband) or +/- 0.50 KHz (wideband) as shown in Figure B-5.



Figure B-5: Receiver CTCSS tone and deviation level

In the Jumper Settings area of the Service section on the RSS, ensure that the “Subtones on audio path” selection is set to “Don’t pass” as shown in Figure B-4. The IFR COM-120 will conduct all tests with CTCSS tones on the audio, giving erroneous measurements, if the Subtones are set to “Pass”.

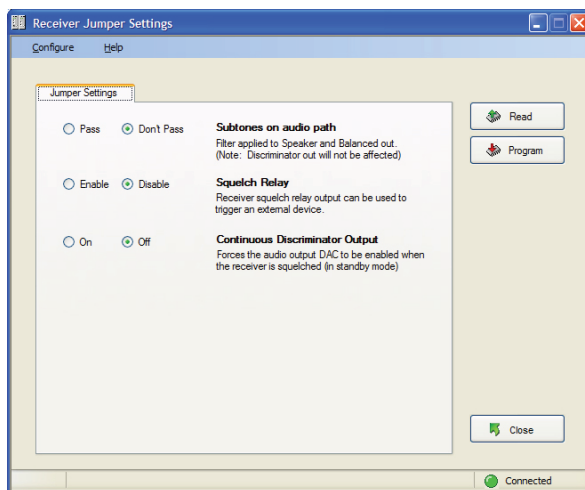

Figure B-6: RSS Subtone Settings

On the Daniels Radio system, ensure the receiver is turned on and turn the System Regulator Speaker switch to ON and INT. Set the FUNCTION rotary switch to position 3 for Rx A or position 5 for Rx B (depending on the receiver being tested), then turn the volume up until the 1 KHz tone is audible.

Audio Distortion

To check the receiver distortion, inject -70 dBm carrier level into the receiver and measure the distortion on the meter. Receiver audio distortion is typically less than 2.0 %.

Enter the Audio Distortion reading on the MT-4E Test Sheet.

Reference Sensitivity

To check the receiver sensitivity, highlight DISTORTION and select SINAD. Highlight LEVEL and push enter on the keypad, then slowly turn the DATA SCROLL spinner down to lower RF generator levels while monitoring the SINAD meter. The 12 dB SINAD point should be at an RF carrier level less than the specified Analog Sensitivity point of the receiver. The IFR COM-120 setup with -122.0 dBm sensitivity is shown in Figure B-7.

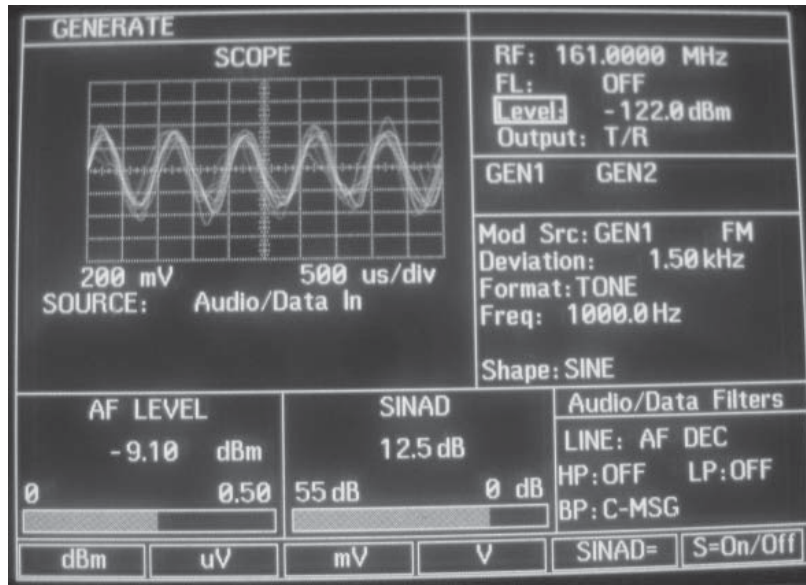

Figure B-7: Receiver Reference Sensitivity Measurement

Enter the Reference Sensitivity (12 dB SINAD) reading on the MT-4E Test Sheet.

If the distortion or reference sensitivity measurements are not within Daniels published specifications, the RF Preselector may need re-alignment. Refer to the Receiver RF Preselector Alignment and Tuning section.

Squelch

Adjust the RF carrier level up and down until the receiver squelches and unsquelches. There should be approximately 6.0 dBm of hysteresis between the squelch and unsquelch points. The squelch point can be adjusted in the Squelch Levels area of the Service section on the RSS.

The Receiver operates on a Noise based squelch (default) or a Received Signal Strength based squelch (optional). The squelch can be set globally for all channels, or on a per channel basis. To set the squelch Open and Close points, inject an RF signal at the desired Open or Close level and click the Set button.

Enter the Squelch and Unsquelch readings on the MT-4E Test Sheet.

Audio Level

The audio level adjustment is not required when connecting the receiver in a repeater configuration using LVDS Serial Data. The audio level adjustment can be done on both the Rx Balanced Audio Output and the Auxiliary Balanced Output (1 and 2). The Auxiliary Balanced Output is only available on the AC-3E Control Card or CI-BC-4E Base Control Card. The Receiver and Auxiliary Balanced Audio Outputs are 600 ohm balanced audio outputs and will require an external 600 ohm matching load before an accurate measurement of the audio level can be performed by the IFR COM-120.

Receiver Balanced Audio Output:

1. Ensure the receiver is turned on and the AC-3E Control Card or CI-BC-4E Base Control Card is NOT plugged into the subrack.

2. In the Audio Levels area of the Service section on the RSS, adjust the Rx Balanced Audio Output level adjustment as shown in Figure B-8 until -8.0 dBm audio level (0.308 Vrms @ 600 ohms) is measured on the AF Level on the IFR COM-120. If no external 600 ohm load is available, the audio level could be adjusted for approximately 0.585 Vrms in the IFR COM-120.

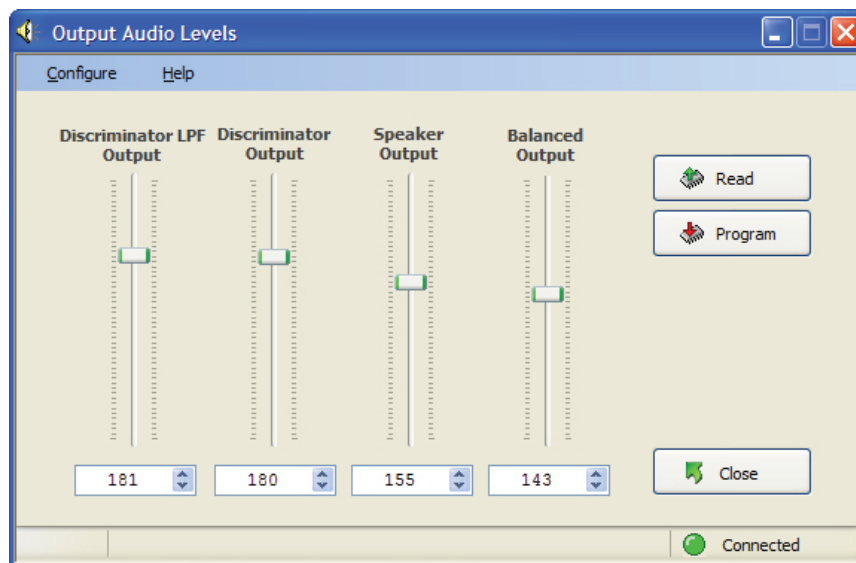

Figure B-8: RSS Receiver Audio Level Adjustment

Auxiliary Balanced Audio Output (1 or 2):

1. Ensure the receiver is turned on and the AC-3E Control Card or CI-BC-4E Base Control Card IS plugged into the subrack using an extender card. Ensure that NO external devices (eg. tone remote adapter or IP router) are connected to the auxiliary audio output.
2. Connect the Auxiliary Balanced Audio Output to the AUDIO/DATA SINAD IN input on the IFR COM-120. Auxiliary 1 audio output is available on pins B11 and A11, and Auxiliary 2 audio output is available on pins C1 and C3 for the AC-3E Control Card and pins C2 and C4 for the CI-BC-4E Base Control Card.
3. Adjust the Auxiliary Balanced Audio Output Level adjustment (R13 for Aux Out 1, R56 for Aux Out 2) for 0.0 dBm audio level (0.775 Vrms @ 600 ohms). If no external 600 ohm load is available, the audio level could be adjusted for approximately 2.500 Vrms in the IFR COM-120.

Enter the Balanced Audio Output Level and Auxiliary Audio Output Level (if used) readings on the MT-4E Test Sheet.

To select between dBm and Vrms highlight AF LEVEL and select ZOOM. Highlight the measurement units and select dBm or Vrms (ensure that the impedance is set to 600 Ohms when selecting dBm) as shown in Figure B-9. Hit RETURN to return to the Generate window.

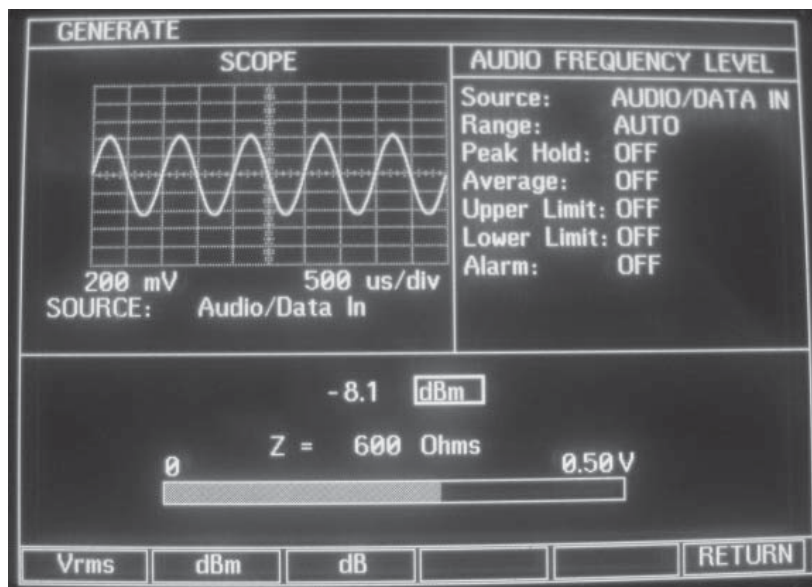

Figure B-9: Receiver Balanced (and Auxiliary) Audio Output Measurement

RF Preselector Alignment and Tuning

Tuning of the RF Preselector filter is typically only required when the Analog or Digital Sensitivity or Analog Distortion do not meet published specifications, or when the receiver RF frequency is changed beyond the band pass of the filter (typically 5 - 7 MHz in a VHF or UHF 400 MHz receiver). The UHF 800 MHz receiver RF Preselector is Full Band and does not require any tuning.

Connect the IFR COM-120 and Daniels Radio as shown in Figure B-10.

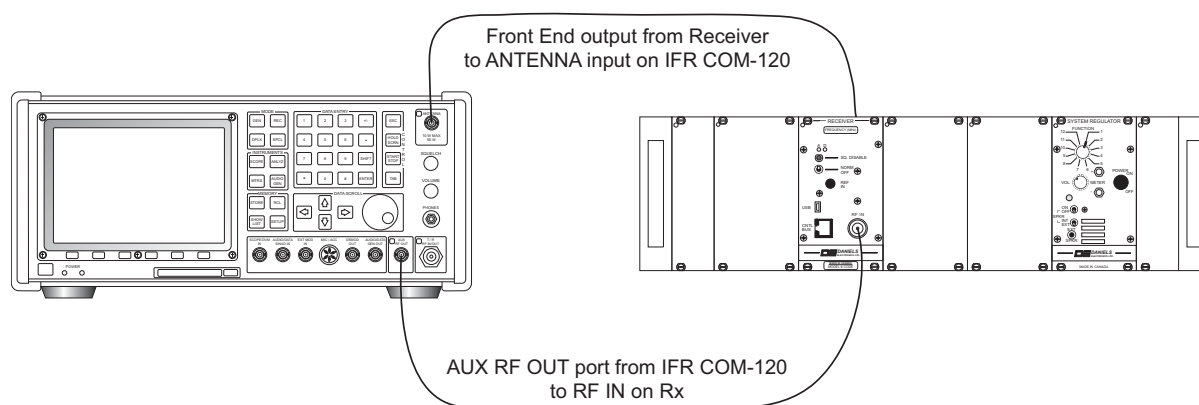

Figure B-10: Receiver RF Preselector Tuning

The RF Preselector output is a small RF cable internal in the receiver that terminates in an SMB connector. The SMB plugs into J3 on the Receiver Mainboard. Disconnect the SMB cable from J3 and use the SMB-BNC adapter to connect this point to the ANTENNA input on the IFR COM-120 as shown in Figure B-11.

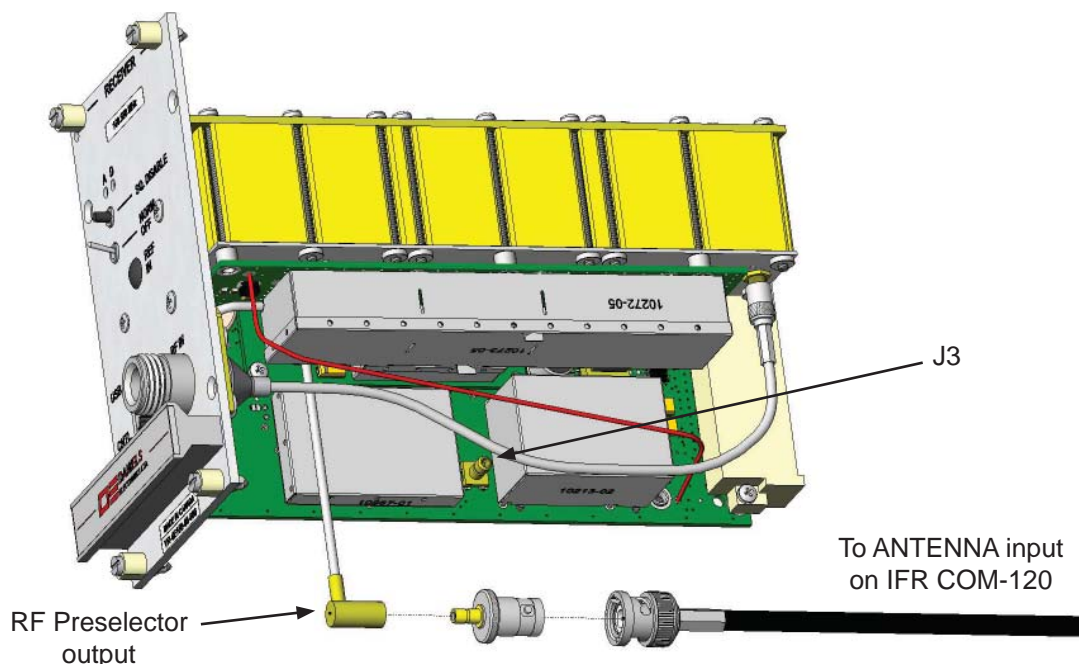

Figure B-11: Receiver RF Preselector Connection

Select the ANALYZ INSTRUMENTS button and set up the IFR COM-120 as shown in Figure B-12.

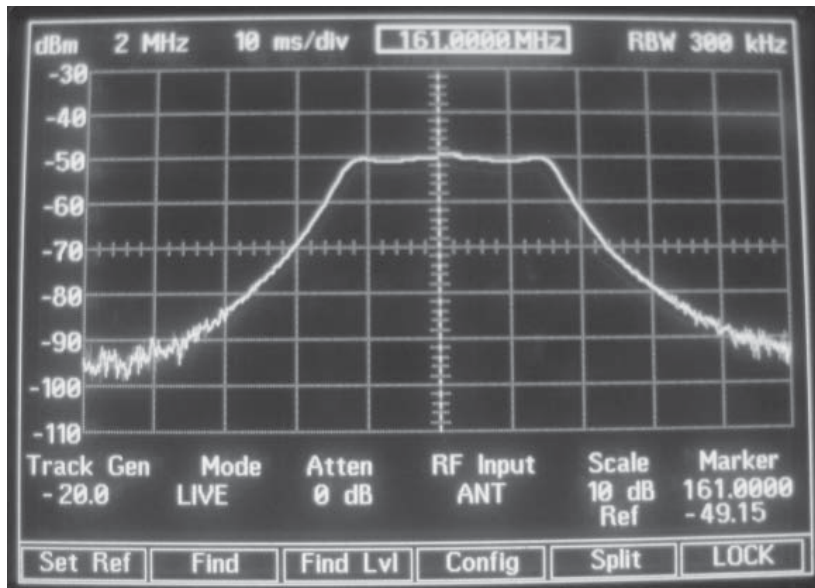

Figure B-12: Receiver RF Preselector on the Spectrum Analyzer

Enter the correct RF frequency and ensure the receiver is turned on. The filter waveform will appear on the scope display. To tune the RF Preselector filter, remove the dust caps on the variable capacitors and, starting from the capacitor closest to the front panel of the receiver and moving back, tune the filter to its new frequency.

Reference Oscillator Adjustment

Connect the IFR COM-120 and Daniels Radio as shown in Figure B-13.

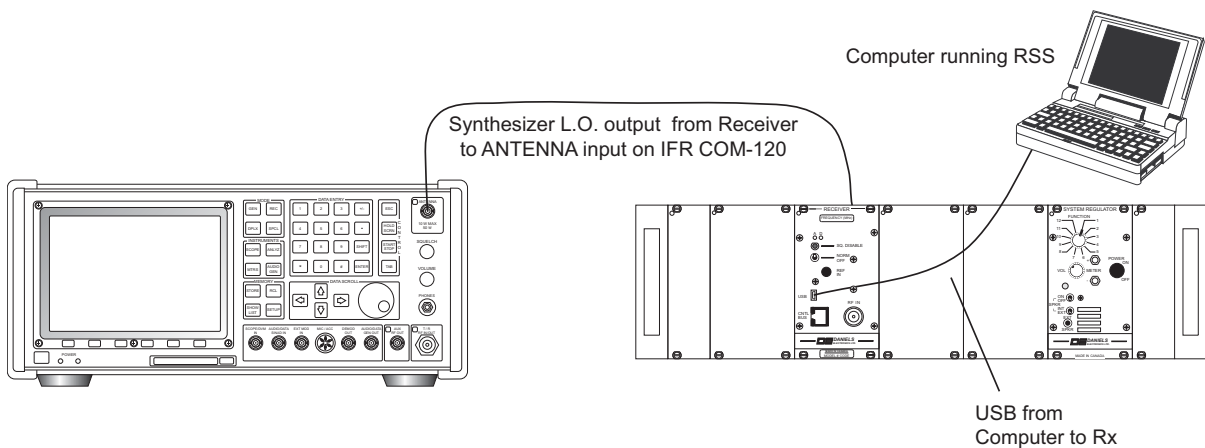

Figure B-13: Receiver Reference Oscillator Testing

The reference oscillator test on the receiver requires a connection directly into the Synthesizer, which uses an SMB connector. Disconnect the SMB cable from the LO output of the synthesizer and connect the small SMB-SMB cable to the SMB jack that is mounted on the Synthesizer (beneath the RF Preselector). The SMB-BNC adapter is required to connect this point to the ANTENNA input on the IFR COM-120 as shown in Figures B-14 (VHF and UHF 400 MHz Receiver) and B-15 (UHF 800 MHz Receiver).

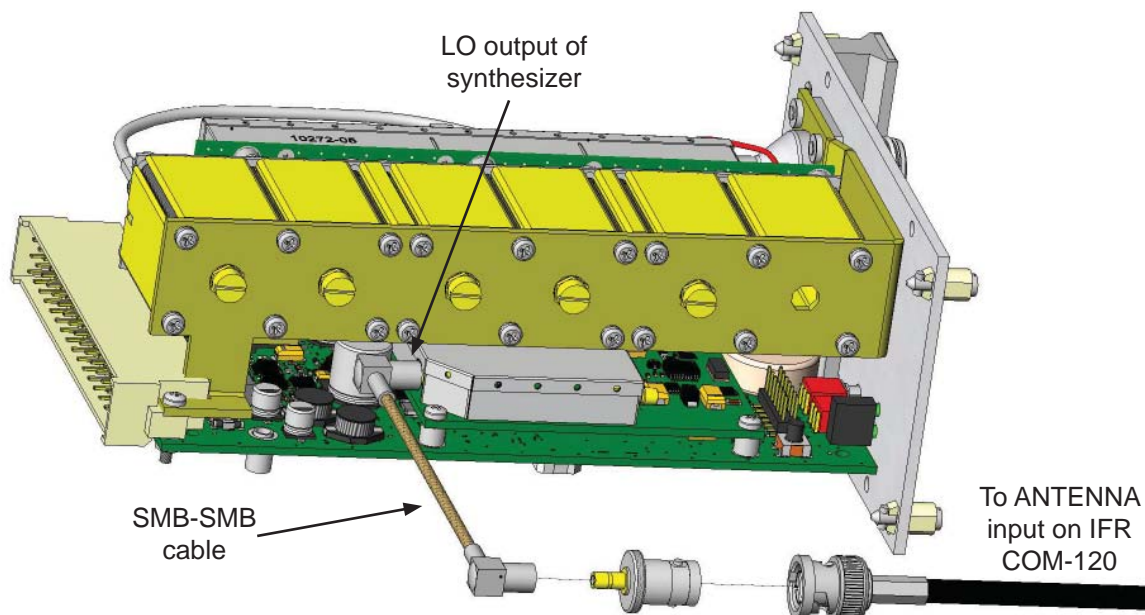

Figure B-14: VHF and UHF 400 MHz Receiver Reference Oscillator Connection

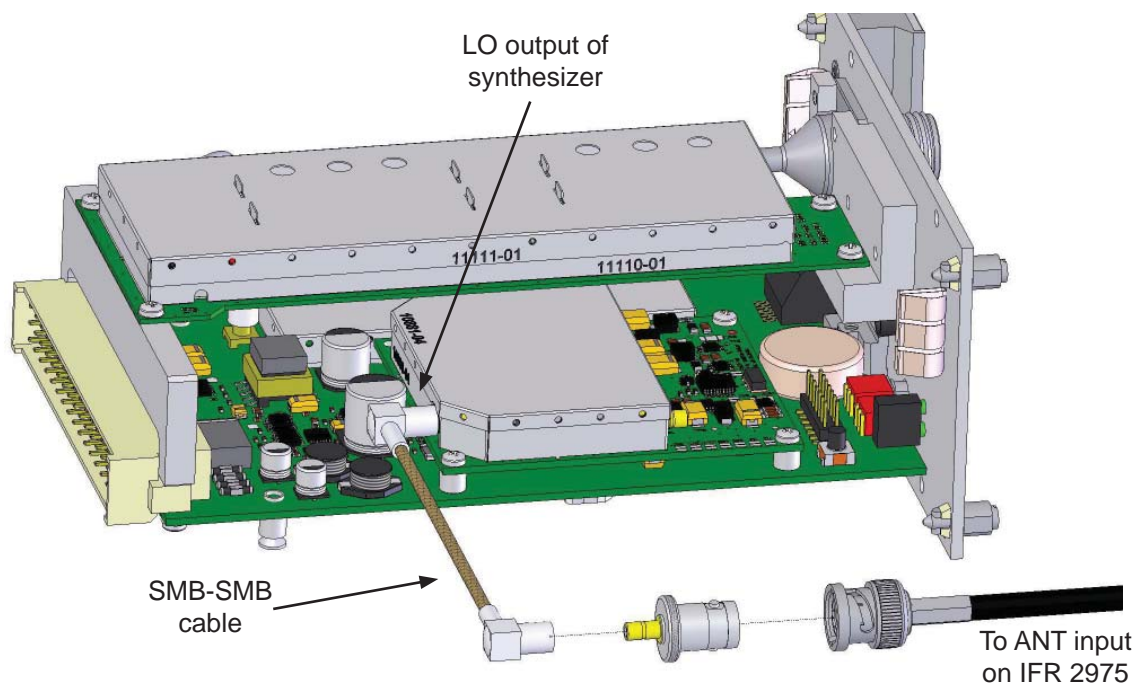

Figure B-15: UHF 800 MHz Receiver Reference Oscillator Connection

Select the REC MODE button and set up the IFR COM-120 as shown in Figure B-16.

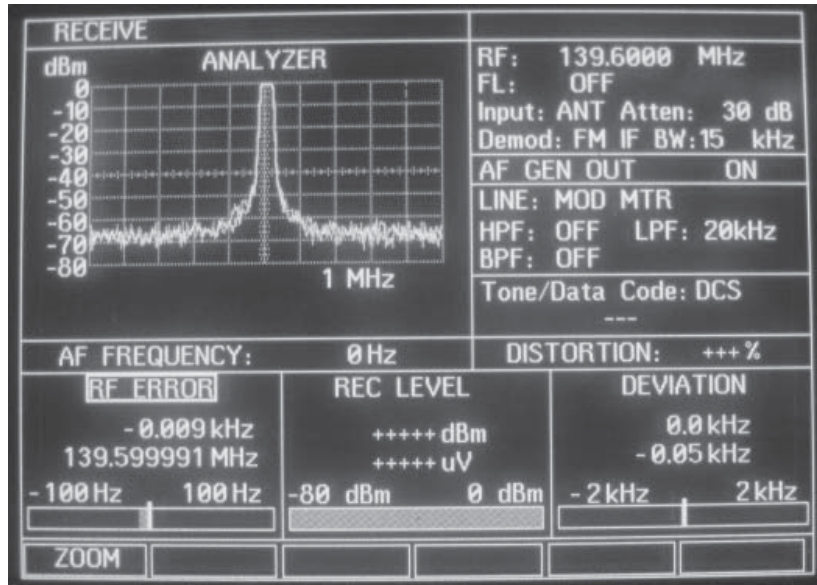

Figure B-16: Receiver Reference Oscillator Measurement

In the receiver RSS, enter the Service section and click on “Ref Oscillator”. The reference oscillator frequency is shown as the “Target Synthesizer RF OUT”. Enter this RF frequency into the IFR COM-120. The receiver generates this frequency out of the Synthesizer into the IFR COM-120.

Monitor the RF Frequency Error on the IFR COM-120. To change the reference frequency, adjust the softpot slider in the RSS as shown in Figure B-17. Adjust until the RF error is as close to 0 Hz as possible. Click on the “Program” button to program in the new Reference Oscillator softpot value.

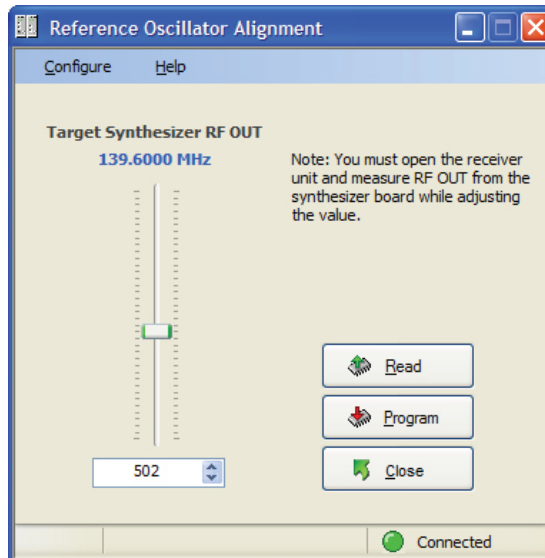

Figure B-17: RSS Receiver Reference Oscillator Alignment

Enter the L.O. Reference Oscillator Offset reading on the MT-4E Test Sheet.

TRANSMITTER TESTING

Connect the IFR COM-120 and Daniels Radio as shown in Figure B-18.

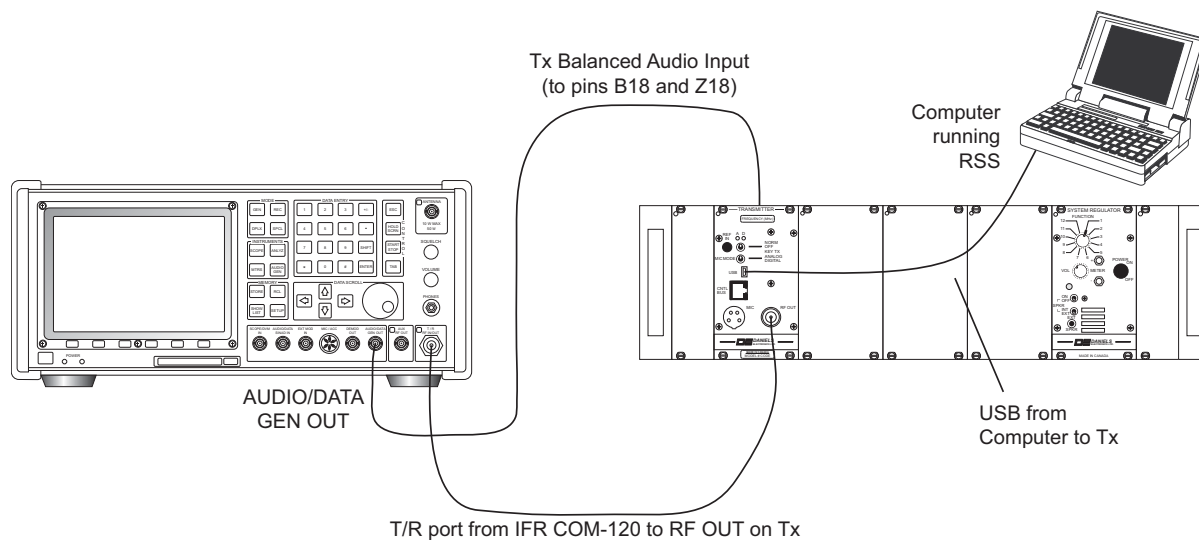

Figure B-18: Transmitter Testing

Select the REC MODE button and set up the IFR COM-120 as shown in Figure B-19.

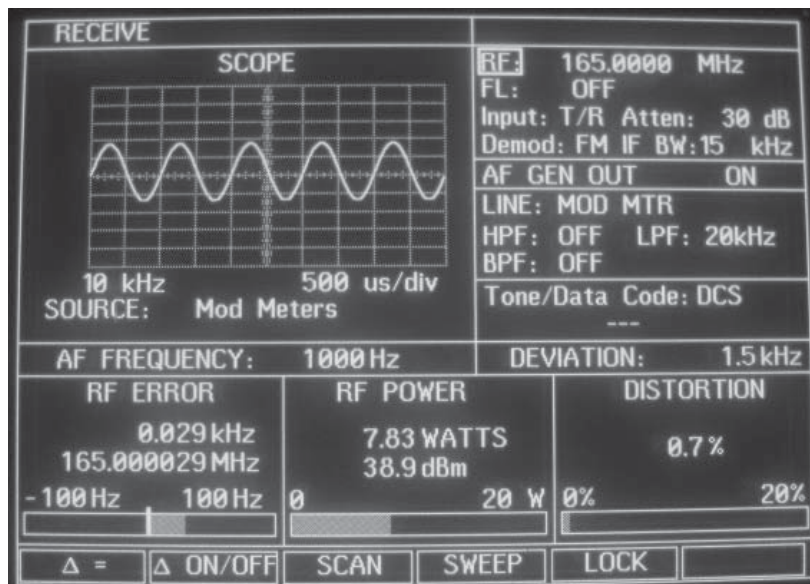

Figure B-19: Transmitter Measurements

Enter the correct RF frequency on the IFR COM-120, set the MIC MODE switch on the front panel of the transmitter to Analog, and flip the other switch to KEY TX (or set the switch to NORM and key the transmitter through the RSS).

Set the receive audio filters and AF Generator frequency and level as follows:

To set the IFR COM-120 receive audio filters, highlight LINE and select CONFIG. Set up the filters as shown in Figure B-20. Hit RETURN to return to the RECEIVE window.

RECEIVER AUDIO/DATA FILTERS SETUP MENU				
LINE	BAND PASS FILTER	HIGH PASS FILTER	LOW PASS FILTER	WIDE-BAND
MOD METERS	OFF	OFF	20kHz	OFF
DTMF/SINAD	C-MSG	OFF	OFF	OFF
AF CNTR/DECODE	OFF	OFF	OFF	ON
DATA DECODER	OFF	OFF	OFF	ON
*** PRESS "EXEC" TO ACTIVATE SELECTION ***				
SPEAKER/PHONES	W.B.			
DEMOD OUT	MOD MTR			
OFF	C-MSG			EXEC RETURN

Figure B-20: Receive Audio Filters

To set the IFR COM-120 AF Generator frequency and level, highlight AF GEN OUT and select ZOOM. Set up GEN1 as shown in Figure B-21. The audio level of 0.43 Vp is 0.304 Vrms or -8.0 dBm. Hit RETURN to return to the RECEIVE window.

Source: GEN1	State: ON
Format: TONE	
Freq: 1000.0 Hz	
Shape: SINE	
Level: 0.43 VP	
	.304 Vrms
Mode: CONT	

Figure B-21: AF Generator

Audio Distortion

The distortion meter will read demodulated audio and give you a transmitter distortion reading as shown in Figure B-19. Transmitter audio distortion is typically less than 2.0 %.

Enter the Audio Distortion reading on the MT-4E Test Sheet.

RF Power

Monitor the RF power output of the transmitter as shown in Figure B-19. In the Power Level area of the Service section on the RSS, click on the “Key Tx” button and adjust the Transmitter Output Power adjustment as shown in Figure B-22 to change the RF output power. Transmitter RF power output will vary slightly with the +10 - +17 Vdc input.

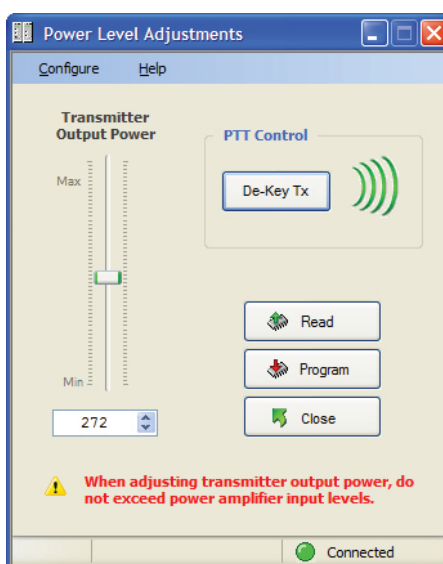

Figure B-22: RSS Transmitter Power Level Adjustment

Enter the RF Power Output reading on the MT-4E Test Sheet.

Connect the transmitter to the power amplifier (if used) and measure the RF power output of the amplifier. Daniels 30 Watt Amplifier’s RF power output can be changed by adjusting the transmitter (exciter) RF power output. Do not exceed power amplifier input levels. Higher power amplifiers typically have a fixed RF power input level and RF power output level.

Enter the Amplifier RF Power Output reading on the MT-4E Test Sheet.

Reference Oscillator Adjustment

Monitor the transmitter reference oscillator (frequency stability / RF error) of the transmitter as shown in Figure B-19. In the transmitter RSS, enter the Service section and click on “Ref Oscillator”. The reference oscillator frequency is shown as the “Target Frequency”. Enter this RF frequency into the IFR COM-120. Click on the “Key Tx” button and the transmitter will generate the reference frequency out of the RF output into the IFR COM-120.

Monitor the RF Frequency Error on the IFR COM-120. To change the reference frequency, click on the “Key Tx” button and adjust the softpot slider in the RSS as shown in Figure B-23. Adjust until the RF error is as close to 0 Hz as possible. Click on the “Program” button to program in the new Reference Oscillator softpot value.

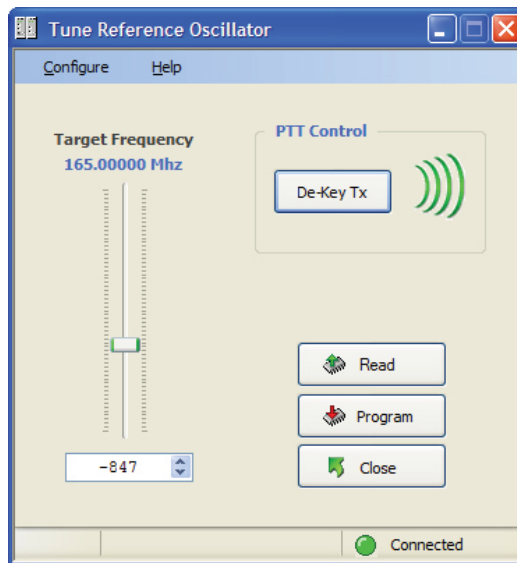

Figure B-23: RSS Transmitter Reference Oscillator Alignment

Enter the Carrier Reference Oscillator Offset reading on the MT-4E Test Sheet.

Deviation Level

The deviation level adjustment is not required when connecting the transmitter in a repeater configuration using LVDS Serial Data. The audio level / deviation level adjustment can be done on both the Tx Balanced Audio Input and the Auxiliary Balanced Input (1 and 2). The Auxiliary Balanced Input is only available on the AC-3E Control Card or CI-BC-4E Base Control Card.

Transmitter Balanced Audio Input:

If the transmitter has CTCSS encode (internal or external), temporarily reprogram the transmitter for no tone.

Ensure that the AC-3E or CI-BC-4E Control Card is NOT plugged into the subrack. In the Audio Levels area of the Service section on the RSS, click on the “Key Tx” button and adjust the Tx Balanced Audio Input level adjustment as shown in Figure B-24 until a deviation of +/- 1.5 KHz (narrowband) or +/- 3.0 KHz (wideband) is measured on the IFR COM-120.

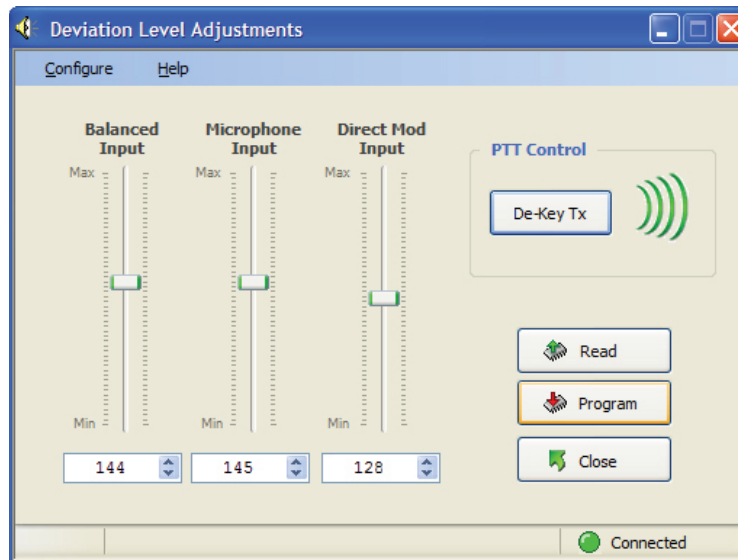

Figure B-24: RSS Transmitter Audio Level Adjustment

Enter the Transmitter Deviation Level reading on the MT-4E Test Sheet.

On the AF Generator, enter an audio level of 2.50 Vp (1.767 Vrms or +7.2 dBm). Ideally, the audio level should be set at +10.0 dBm, but the IFR COM-120 is not capable of more than 2.50 Vp audio level (the difference between the ideal +10.0 dBm and +7.2 dBm is negligible for this test). Enter an audio frequency of 300.0 Hz and increase the 300.0 Hz sine wave in 100.0 Hz increments to 3400.0 Hz and check that the transmitter deviation does not rise above +/- 2.5 KHz (narrowband) or +/- 5.0 KHz (wideband). The MT-4E Transmitter will transmit a maximum deviation at an audio frequency of approximately 1300 Hz.

Enter the Transmitter Maximum Deviation Level reading on the MT-4E Test Sheet.

Auxiliary Balanced Audio Input:

To adjust the auxiliary balanced audio input, plug the AC-3E Control Card or CI-BC-4E Base Control Card into the subrack using an extender card, and connect the AUDIO/DATA GEN OUT on the IFR COM-120 to the Auxiliary Balanced audio input (1 or 2). Auxiliary 1 audio input is available on pins C19 and C20, and Auxiliary 2 audio input is available on pins B14 and A14. Ensure that NO external devices (eg. tone remote adapter or IP router) are connected to the auxiliary audio input. On the AF Generator set the 1 KHz tone to an audio level of 1.10 Vp (0.777 Vrms or 0.0 dBm). Adjust the Auxiliary Balanced Audio Input level adjustment (R120 for Aux In 1, R123 for Aux In 2) for deviation of +/- 1.5 KHz (narrowband) or +/-3.0 KHz (wideband).

Enter the Auxiliary Deviation Level (if used) reading on the MT-4E Test Sheet.

If the CTCSS tone was temporarily programmed for no tone, reprogram the internal or external setting.

CTCSS Testing

MT-4E Transmitters can be programmed, per channel, to generate CTCSS tones internally, or to allow for External Input of the CTCSS tones from another device (such as a tone-remote adapter).

Connect the IFR COM-120 and Daniels Radio as shown in Figure B-25. The Tx Subtone input connection is only required when testing the External Input. If the internal programming is used to generate the CTCSS tone, disconnect the Tx Subtone input from the IFR COM-120.

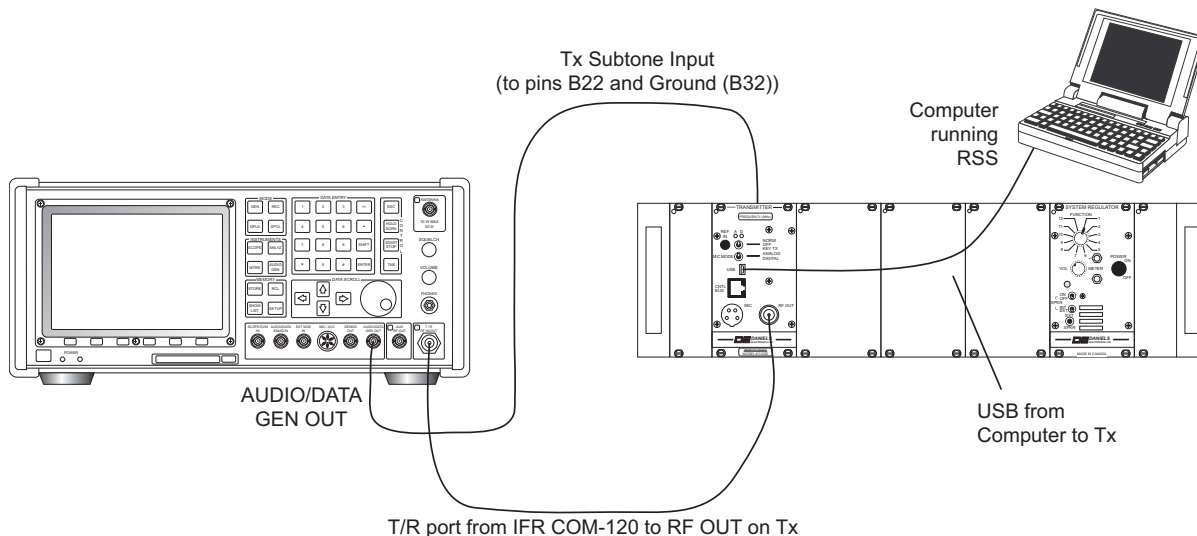

Figure B-25: Transmitter CTCSS Testing

Set the MIC MODE switch on the front panel of the transmitter to Analog, and flip the other switch to KEY TX (or set the switch to NORM and key the transmitter through the RSS).

To set the IFR COM-120 receive audio filters, highlight LINE and select CONFIG. Set up the filters as shown in Figure B-26. Hit RETURN to return to the RECEIVE window.

RECEIVER AUDIO/DATA FILTERS SETUP MENU				
LINE	BAND PASS FILTER	HIGH PASS FILTER	LOW PASS FILTER	WIDE-BAND
MOD METERS	OFF	OFF	300Hz	OFF
DTMF/SINAD	C-MSG	OFF	OFF	OFF
AF CNTR/DECODE	OFF	OFF	OFF	ON
DATA DECODER	OFF	OFF	OFF	ON
*** PRESS "EXEC" TO ACTIVATE SELECTION ***				
SPEAKER/PHONES	W.B.			
DEMOD OUT	MOD MTR			
OFF	300Hz	4kHz	20kHz	EXEC RETURN

Figure B-26: Receive Audio Filter for CTCSS

On the AF Generator (if used), enter an audio level of 0.14 Vp (0.098 Vrms or -18.0 dBm) to inject into the Tx Subtone input. If the internal programming is used to generate the CTCSS tone, the AF Generator is not used and the CTCSS tone is generated internally in the transmitter.

In the Subtone Levels area of the Service section on the RSS, click on the “Key Tx” button and adjust the Narrow and/or Wide Internal and/or External Subtone Deviation level adjustment as shown in Figure B-27 until a deviation of +/- 0.35 KHz (narrowband) or +/-0.5 KHz (wideband) is measured on the IFR COM-120.

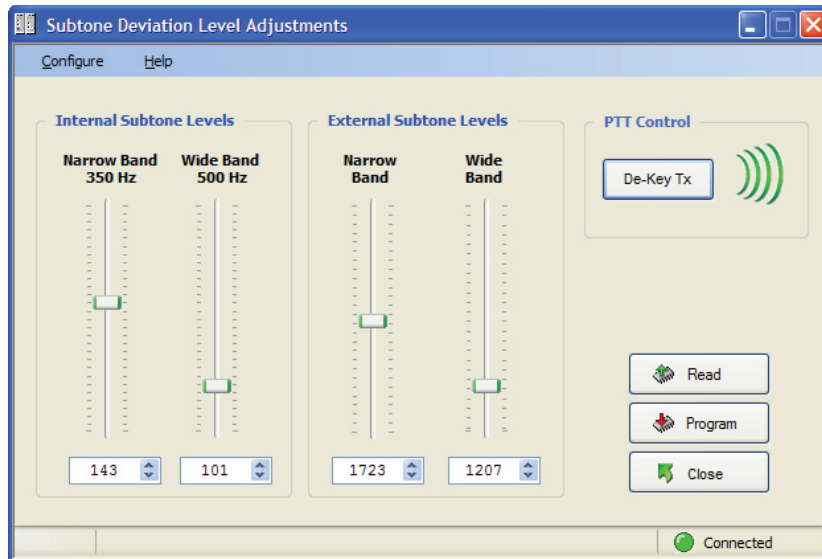

Figure B-27: RSS Transmitter Subtone Deviation Level Adjustment

The CTCSS tone and deviation level will be shown on the IFR COM-120 as shown in Figure B-28.

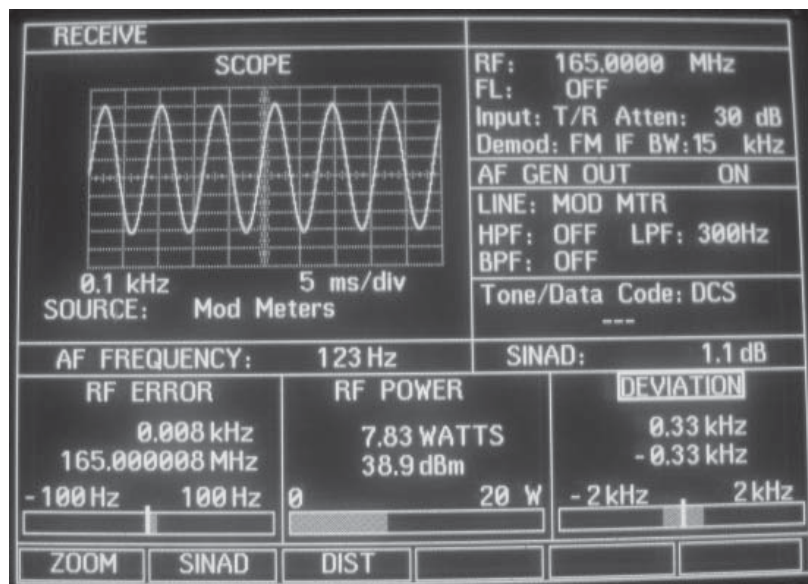

Figure B-28: Transmitter CTCSS Measurements

Enter the CTCSS Encode Deviation level reading on the MT-4E Test Sheet.

SYSTEM TESTING

Connect the IFR COM-120 and Daniels Radio as shown in Figure B-29:

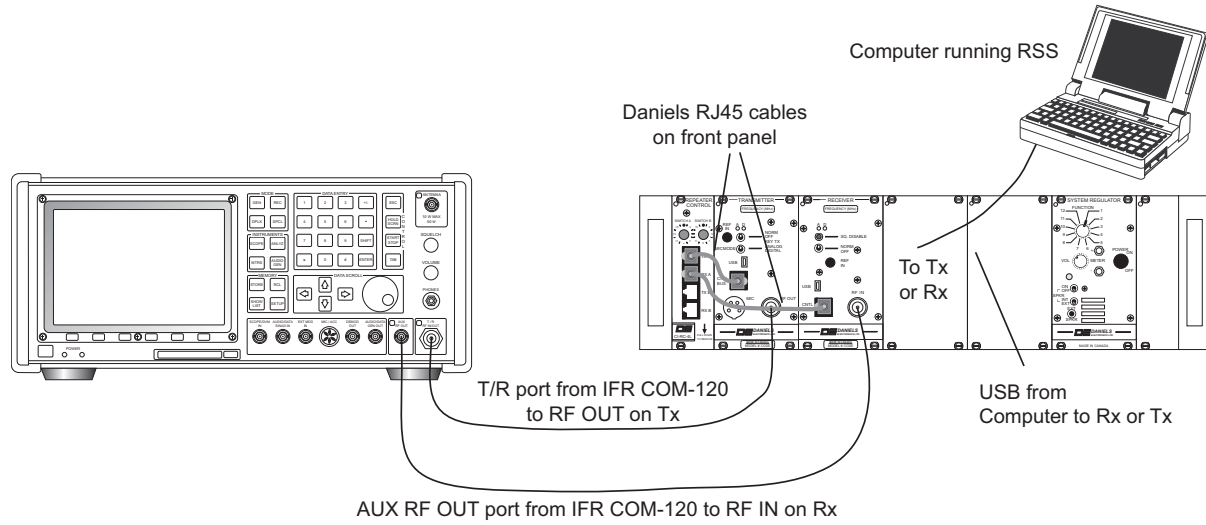

Figure B-29: System Duplex Testing

Select the DPLX MODE button and set up the IFR COM-120 as shown in Figure B-30.

DUPLX		RECEIVE AND GENERATE	
RECEIVE		GENERATE	
RF:	165.0000 MHz	RF:	161.0000 MHz
FL:	OFF	Offset:	-4.0000 MHz
Input:	T/R Atten: 0 dB	Level:	-70.0 dBm
Demod:	FM IF BW: 30 kHz	Output:	AUX
Tone/Data Code:	DTMF	GEN1	GEN2
Deviation:	1.51 kHz	Mod Src:	GEN1 FM
AF Frequency:	1000 Hz	Deviation:	1.50 kHz
Distortion:	2.0%	Format:	TONE
RF Power:	7.79 WATTS	Freq:	1000.0 Hz
RF Error Freq:	0.002 kHz	Shape:	SINE
SINAD			

Figure B-30: System Duplex Measurements

Set the receiver and transmitter front panel switch to NORM. The MIC MODE switch on the transmitter front panel can be set to either Digital or Analog (this test does not make use of the front panel switch). Enter the correct RF frequencies for the receiver and transmitter and ensure that the deviation level of the 1.0 KHz tone is set at +/- 60% maximum deviation (+/- 1.5 KHz (narrowband) or +/- 3.0 KHz (wideband)). Enter the correct CTCSS tone (if used) and deviation level for the tone (+/- 0.35 KHz (narrowband) or +/- 0.50 KHz (wideband)).

Ensure that the receiver and transmitter are connected to the repeater controller via the RJ45 cables on the front panel (In some systems, the Rx and Tx may be connected directly together using the RJ45 cables).

Demodulated Audio Frequency

Check the AF Frequency to ensure it is the same frequency as the modulated input frequency.

Distortion

To check the complete receiver system distortion, inject -70 dBm carrier level into the receiver and measure the distortion on the meter.

Enter the System Distortion reading on the MT-4E Test Sheet.

Deviation Level

If the transmitter has CTCSS encode (internal or external), temporarily reprogram the transmitter for no tone.

Check the repeater deviation level. Ideally the deviation level out of the transmitter should match the input to the receiver. The repeater deviation level matching is adjusted by the analog LVDS level adjustment that is available in both the receiver and transmitter (only one needs to be adjusted).

In the receiver or transmitter RSS, enter the Service section and click on “LVDS Level”. A default value of 100 on the softpot slider should be close to matching receiver and transmitter deviation levels, however minor adjustments can be made. Adjust the softpot slider in the RSS as shown in Figure B-31 until a deviation of +/- 1.5 KHz (narrowband) or +/- 3.0 KHz (wideband) is measured on the IFR COM-120.

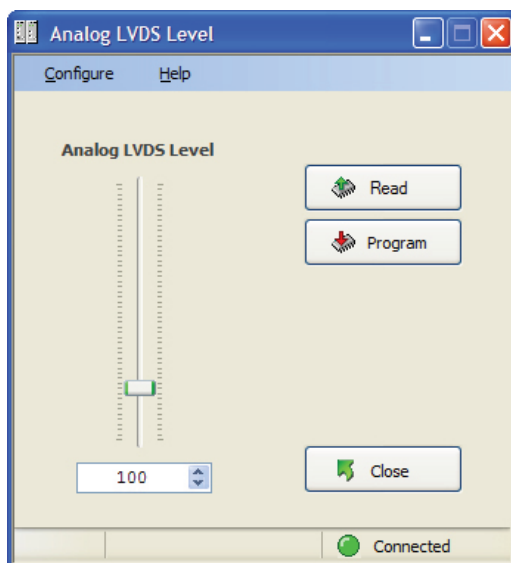

Figure B-31 RSS Receiver or Transmitter Analog LVDS Level Adjustment

Enter the Repeat Deviation Level reading on the MT-4E Test Sheet.

If the CTCSS tone was temporarily programmed for no tone, reprogram the internal or external setting.

Daniels Electronics Ltd.
43 Erie Street, Victoria, BC
Canada, V8V 1P8
www.danelec.com
sales@danelec.com

Toll Free Canada and USA
Phone: 1-800-664-4066
Fax: 1-877-750-0004

International
Phone: 250-382-8268
Fax: 250-382-6139

©2011 Daniels Electronics Ltd. All Rights Reserved.

MG-00B-4-0-0



www.danelec.com